



# MAINTENANCE MANUAL SAVANNAH S

Doc. No.:	MM-SVNH-EN
Revision:	07
Rev. Date:	07/11/2022
Proj. Ref.:	SVNH S

**I.C.P. Srl**



**MM-SVNH-EN**

# MAINTENANCE MANUAL ICP SAVANNAH S™

**Serial Number:**

**Generic YY-MM-54-XXXX**

**Year 20YY**

	Function	Name	Signature
<b>Prepared</b>	TECNIC - Technical Manager	Federico Peronato	
	CONF - Configuration Manager	Andrea Lisa	
<b>Verified</b>	TECNIC - Technical Manager	Federico Peronato	
<b>Approved</b>	DIG - Accountable Manager	Tancredi Razzano	

**Manufacturer data:**

<b>Name:</b>	I.C.P. Srl	<b>Contacts:</b>	Phone	+39 011 9927503
<b>Address:</b>	S.P. 16 km 15,150 Castelnuovo Don Bosco (AT) Italy , 14022		Website:	www.icp.it
			Email:	info@icp.it
			Airworthiness:	tecnico@icp.it

*The technical data and the information embodied therein are property of I.C.P. Srl and shall not be disclosed in whole or in part to third parties, without prior written permission of I.C.P. Srl. The manual must remain with the aircraft in case of sale.*

	<b>MAINTENANCE MANUAL SAVANNAH S</b>	<b>Doc. No.:</b> MM-SVNH-EN
		<b>Revision:</b> 07
		<b>Rev. Date:</b> 07/11/2022
		<b>Proj. Ref.:</b> SVNH S

## 0.1. Amendment record

Revision	Date	Description	Issued by
00	15/11/2009	First issue	Andrea Caglio
01	21/07/2010	Ch. 3, 4, Pag. 11, 12	Andrea Caglio
02	29/04/2010	Ch. 3, Pag. 9	Andrea Caglio
03	19/05/2011	Ch. 3	Andrea Caglio
04	11/03/2015	General revision, all Pag.	Michele Bassetti
05	22/06/2016	Ch. 3.7, Pag. 11, 12	Michele Bassetti
06	18/12/2018	Ch. 1, Pag. 1, 3	Federico Peronato
07	07/11/2022	New issue of the Maintenance Manual, superseding all the previous versions	Federico Peronato





# MAINTENANCE MANUAL SAVANNAH S

<b>Doc. No.:</b>	MM-SVNH-EN
<b>Revision:</b>	07
<b>Rev. Date:</b>	07/11/2022
<b>Proj. Ref.:</b>	SVNH S

## 0.2. Table of content

0.1.	Amendment record .....	2
0.2.	Table of content .....	3
0.3.	Figure Index.....	6
0.4.	Table Index.....	7
0.5.	List of Effective Pages .....	8
1.	General Information .....	9
1.1.	Meaning of WARNING, CAUTION and NOTE .....	10
1.2.	Technical documentation .....	11
1.3.	Aircraft identification placard .....	11
1.4.	Authorized personnel.....	11
1.5.	Spare parts purchase.....	12
1.6.	Warranty .....	13
1.7.	Maintenance Request Form to ICP manufacturer .....	13
1.8.	Feedback Form to ICP manufacturer .....	13
1.9.	Aircraft protection and anchoring .....	14
1.10.	Aircraft cleaning .....	14
1.11.	Consumable materials.....	15
1.12.	Nominal diameters .....	16
1.13.	Tightening torques.....	16
1.14.	Safetying practices .....	19
1.14.1.	Safety wires .....	19
1.14.2.	Castle nut and cotter pin .....	20
1.14.3.	Threaded fasteners .....	21
1.14.4.	Bolt-Nut cross-check mark .....	22
1.14.5.	Pop riveting .....	22
1.14.6.	Solid riveting .....	22
1.14.7.	Cable nonio tender.....	23
1.14.8.	Hose assembly.....	23
1.15.	Tools .....	25
1.15.1.	Standard maintenance tools.....	25
1.15.2.	Unusual maintenance tools .....	25
1.15.3.	Auxiliary tools (part of the aircraft kit) .....	26



# MAINTENANCE MANUAL SAVANNAH S

<b>Doc. No.:</b>	MM-SVNH-EN
<b>Revision:</b>	07
<b>Rev. Date:</b>	07/11/2022
<b>Proj. Ref.:</b>	SVNH S

1.15.4.	Measuring tools.....	26
1.16.	Terms and Definitions .....	26
1.17.	Airworthiness Limitations.....	27
1.18.	Maintenance interval tolerances .....	27
1.19.	Aircraft lifting .....	27
1.19.1.	Engine lifting .....	28
1.20.	Aircraft Levelling.....	28
1.21.	Aircraft weighing.....	28
1.22.	Fuel and fluids draining .....	29
1.24.	Aircraft approved documentation.....	30
1.25.	Unit conversions.....	30
2.	Daily Pre-Flight Check .....	31
3.	Time limits .....	35
4.	Maintenance Schedule .....	37
4.1.	50 Hours maintenance checklist .....	39
4.2.	100 Hours / 1 Year maintenance checklist.....	55
4.3.	200 Hours maintenance checklist .....	57
4.4.	1000 hours maintenance checklist.....	59
4.5.	2000 Hours maintenance checklist .....	64
5.	Unscheduled Maintenance.....	67
5.1.	Heavy landing .....	67
5.2.	Fuel system leakage in fuselage.....	68
5.3.	Wing tank or cup fuel leakage.....	68
5.4.	Radiator suspension breakage .....	68
5.5.	Windshield or window cracks or breakage .....	68
5.6.	Object strike the structure .....	69
5.7.	Propeller strike.....	69
5.8.	Engine failure.....	69
5.9.	Engine parameter exceeding .....	69
5.10.	Noncompliance with fuel quality .....	69
5.11.	Noncompliance with engine fluid quality .....	69
5.12.	Noncompliance with brake oil quality.....	70
5.13.	Electric circuit overload (breaker out) .....	70
5.14.	Flight envelope exceeding.....	70



# MAINTENANCE MANUAL SAVANNAH S

<b>Doc. No.:</b>	MM-SVNH-EN
<b>Revision:</b>	07
<b>Rev. Date:</b>	07/11/2022
<b>Proj. Ref.:</b>	SVNH S

5.14.1.	Airspeed exceeding.....	70
5.14.2.	Airspeed exceeding with high turbulence .....	70
5.14.3.	Load factor exceeding .....	70
5.14.4.	Flap overspeed .....	71
5.14.5.	Take-off mass exceeding .....	71
6.	Aircraft and Systems description.....	73
6.1.	Airframe .....	73
6.2.	Controls .....	78
6.3.	Powerplant.....	79
6.3.1.	Engine .....	79
6.3.2.	Propeller .....	79
6.4.	Fuel system .....	80
6.5.	Oil system.....	82
6.6.	Cooling system .....	83
6.7.	Brake system .....	85
6.8.	Cabin heating and ventilation.....	86
6.9.	Electrical system.....	87
6.10.	Configuration, equipment, instruments and avionics.....	89
6.11.	Painting.....	95
7.	Maintenance descriptions .....	97
7.1.	Control surface travel setting .....	97
7.1.1.	Flaperon as aileron .....	97
7.1.2.	Flap indications.....	100
7.1.3.	Flight check of Flaperons.....	100
7.1.4.	Elevator control system.....	100
7.1.5.	Rudder control system .....	103
7.1.5.1.	Rudder pedals alignment to rudder and nose wheel .....	103
7.1.5.2.	Rudder ground adjustable (flettner) tab deflection.....	104
7.1.6.	Elevator Trim Tab setup.....	104
7.1.7.	Tail wheel landing gear (if configured with) .....	105
7.1.8.	Brake pedals position on Rudder pedals.....	105
7.2.	Control surface free play with controls locked .....	105
7.3.	Control surfaces hinges .....	106
7.4.	Fuel system drainage.....	106



# MAINTENANCE MANUAL SAVANNAH S

<b>Doc. No.:</b>	MM-SVNH-EN
<b>Revision:</b>	07
<b>Rev. Date:</b>	07/11/2022
<b>Proj. Ref.:</b>	SVNH S

7.5. Brakes system bleeding .....	106
7.5.1. Brakes oil pumps acceptable leaking .....	107
7.6. Brake pads change .....	107
7.7. Engine oil level verification .....	108
7.8. Oil change .....	108
7.9. Coolant level verification .....	109
7.10. Coolant change .....	109
7.11. Air filter .....	110
7.12. Tyre change .....	110
7.13. Windshield cracks .....	111
7.14. Wheel fairing cracks .....	111
8. Maintenance / Service Bulletin / Change & Repair record tables .....	113
ANNEX A - Request of Technical Intervention on the Aircraft .....	119
ANNEX B - Feedback about ICP Aircraft .....	121
ANNEX C - Maintenance work record Model .....	123

## 0.3. Figure Index

Figure 1: Safety wires example .....	20
Figure 2: Cotter pin example .....	20
Figure 3: Threaded fasteners .....	22
Figure 4: Nonio cable tender .....	23
Figure 5: Fuel hose on fitting .....	23
Figure 6: Fuel hose on corrugated pipe .....	24
Figure 7: Oil hose on corrugated pipe .....	24
Figure 8: Water hose on corrugated pipe .....	24
Figure 9: Daily pre-flight check sequence plan view .....	31
Figure 10: Main landing gear spring design nominal dimensions (unloaded) .....	67
Figure 11: Cabin floor .....	74
Figure 12: Fuselage rear cone .....	74
Figure 13: Cabin frame and windshield .....	75
Figure 14: Left wing .....	75
Figure 15: Left inboard flaperon .....	76
Figure 16: Left outboard flaperon .....	76
Figure 17: Stabilizer .....	76
Figure 18: Elevator .....	77
Figure 19: Fin and Rudder .....	77
Figure 20: Longitudinal and lateral controls .....	78

	<h1 style="margin: 0;">MAINTENANCE MANUAL</h1> <h2 style="margin: 0;">SAVANNAH S</h2>	Doc. No.: MM-SVNH-EN
		Revision: 07
		Rev. Date: 07/11/2022
		Proj. Ref.: SVNH S

Figure 21: Directional controls.....	78
Figure 22: Airframe fuel system parts.....	80
Figure 23: Wing standard fuel system.....	80
Figure 24: Wing double fuel tank system (interconnected tanks).....	81
Figure 25: Wing double fuel tank system with transfer pumps.....	81
Figure 26: Fuselage and Rotax 912 UL/ULS fuel system.....	81
Figure 27: Fuselage Rotax 912 iS fuel system.....	82
Figure 28: Rotax 912 UL/ULS/iS standard oil system.....	82
Figure 29: Rotax 912 UL/ULS/iS oil system with thermostat.....	83
Figure 30: Rotax 912 UL/ULS/iS standard cooling system.....	84
Figure 31: Rotax 912 UL/ULS/iS cooling system with thermostat.....	84
Figure 32: Standard brake system (only right side is shown, the left is identical, symmetrical).....	85
Figure 33: Brake system with parking brake (only right side is shown, the left is identical, symmetrical).....	85
Figure 34: Double side brake system (only right side is shown, the left is identical, symmetrical).....	86
Figure 35: Cabin heating system.....	86
Figure 36: Electrical wiring of engine compartment.....	87
Figure 37: Electrical wiring firewall backward.....	88
Figure 38: Flaperon jig SA200VG and position on the first wing rib.....	98
Figure 39: Position of jig SA200VG near the first rib rivets line, aligned to wing trailing edge.....	98
Figure 40: ZERO setting of the left inner Flaperon. Marks of +/- 0.5° of tolerance.....	99
Figure 41: Push-pull rods for Flaperon setup.....	99
Figure 42: Digital spirit level position on Stabilizer for Zeroing.....	101
Figure 43: Longitudinal line bell crank on the full nose up position, against stop.....	102
Figure 44: Digital spirit level position on Elevator.....	102
Figure 45: Elevator final setup deflection angle.....	103
Figure 46: Control surfaces hinges.....	106
Figure 47: Brake pump (seen horizontally, not vertically like the airplane installation).....	107

### 0.4. Table Index

Table 1: Authorized personnel in function of the maintenance work.....	12
Table 2: Consumable materials.....	15
Table 3: Nominal diameters.....	16
Table 4: Tightening torques for standard application.....	16
Table 5c (a-c): Tightening torques for unusual application.....	19
Table 6: Cotter pin coupling with castle nut.....	21
Table 7: Standard tools.....	25
Table 8: Unusual tools.....	25
Table 9: Auxiliary tools.....	26
Table 10: Measuring tools.....	26
Table 11: Terms and Definitions.....	26
Table 12: Tires pressure.....	29
Table 13: Approved documents.....	30

	<b>MAINTENANCE MANUAL SAVANNAH S</b>	<b>Doc. No.:</b> MM-SVNH-EN
		<b>Revision:</b> 07
		<b>Rev. Date:</b> 07/11/2022
		<b>Proj. Ref.:</b> SVNH S

Table 14: Conversions .....	30
Table 15: Daily pre-flight check list.....	34
Table 16b (a-b): Time limits .....	36
Table 17: Maintenance schedule .....	37
Table 18: Main maintenance tasks.....	38
Table 19q (a-q): 50 [hrs] scheduled maintenance .....	54
Table 20b (a-b): 100 [hrs] scheduled maintenance .....	56
Table 21b (a-b): 200 [hrs] scheduled maintenance .....	58
Table 22e (a-e): 1000 [hrs] scheduled maintenance .....	63
Table 23c (a-c): 2000 [hrs] scheduled maintenance.....	66
Table 24: Engines.....	79
Table 25. Propellers.....	79
Table 26: Fuel system volumes.....	82
Table 27: Oil system capacity .....	83
Table 28: Cooling system capacity.....	83
Table 29: Battery type .....	87
Table 30: Minimum Equipment List .....	89
Table 31: Standard configuration .....	90
Table 32d (a-d): Optional configuration, avionics and equipment.....	94
Table 33: Painting products .....	95
Table 34: Lateral CS push-pull rods dimensions .....	100
Table 35: Longitudinal CS push-pull rod dimension .....	103
Table 36: Directional CS (steering) push-pull rods dimension .....	104
Table 37: Trim tab push-pull rods dimension.....	105
Table 38: Engine oil level .....	108
Table 39: Coolant level .....	109
Table 40d (a-d): Maintenance record table.....	116
Table 41: Service Bulletin performed table.....	117
Table 42: Change or Repair performed.....	118

## 0.5. List of Effective Pages

The present Maintenance Manual contains *8 Chapters*, *3 Annexes* and *132 Pages*, all approved by I.C.P. Srl.



	<h1 style="color: blue;">MAINTENANCE MANUAL SAVANNAH S</h1>	Doc. No.: MM-SVNH-EN
		Revision: 07
		Rev. Date: 07/11/2022
		Proj. Ref.: SVNH S

## 1. General Information

Each *Savannah S<sup>TM</sup>* is supplied with a *Pilot Operating Handbook*, a *Maintenance Manual* and a *Spare Parts Catalogue*; these manuals are considered as parts of the aircraft and they must follow the aircraft during its entire life.

Maintenance instructions herein described are the only ones approved for a safe maintaining of the *Savannah S<sup>TM</sup>* and must be strictly followed.

It's important to periodically verify that all the airplane manuals version are current, monitoring the updates on the website of the manufacturer [www.icpaviazione.it](http://www.icpaviazione.it) at *My I.C.P.* section, by logging in. If the version is not current, update the manuals. Verify also that the airplane is free from the application of any new *Service Bulletin*, or already applied.

Any additional information can be requested directly to the email [info@icp.it](mailto:info@icp.it).

For the engine maintenance, ballistic rescue system (if installed) and any other additional equipment maintenance, refer to relevant manufacturers manuals. The present manual do not show any equipment information.

### WARNING

**The owner and finally the pilot should verify that every maintenance and checks are carried out as prescribed by the manufacturer of each system, including airframe**

### WARNING

**Any modification to the aircraft that could potentially affect the structural integrity or flight characteristics that has not been specifically approved by ICP in written form, will render all warrantees invalid and absolve ICP and ICP dealers of any further responsibility to the owner and or operator and liability for the consequences of such modification. Furthermore, the parts shall be replaced, for maintenance and repair, with the genuine spare parts supplied by the ICP Manufacturer or authorized dealers**

This manual describes the operations to be carried out for the appropriate inspection, maintenance and repair of the *Savannah S<sup>TM</sup>* aircraft. Failure to follow the instruction herein reported will affect the efficiency of the aircraft and the flight safety.

### NOTE

All the maintenance and repair operations should be recorded on the table at the end of this manual or in a separate Aircraft Maintenance Logbook

### WARNING

**For complete engine checks and maintenance see the original Rotax Maintenance Manual and Service Bulletins emitted by B.R.P. Rotax**

	<h1 style="color: blue;">MAINTENANCE MANUAL SAVANNAH S</h1>	Doc. No.: MM-SVNH-EN
		Revision: 07
		Rev. Date: 07/11/2022
		Proj. Ref.: SVNH S

**CAUTION**

Because of the continuous issuing of Service Bulletin and Service Information by Rotax, I.C.P. Srl does not intend to forward such information to the owners of Rotax engines.

These information are available on the website [www.rotax-aircraft-engines.com](http://www.rotax-aircraft-engines.com) in the *Technical Documentation* page; we also recommend to contact the authorized Rotax national dealer to receive further information.

I.C.P. Srl does not take any responsibility for any damage to people and/or property due to failures in applying Rotax instructions

**WARNING**

**For other equipment checks and maintenance, always refer to the original approved Maintenance Manual and Service Bulletins issued by the manufacturer of each relative system (i.e. Propeller, parachute rescue system). I.C.P. Srl does not take any responsibility for any damage to people, property and aircraft due to failures in applying any Service Bulletins, including the ones of the aircraft**

**WARNING**

**Inspection and maintenance operations at 1000 and 2000 hours are particularly delicate; for any doubt, contact the national dealer or the manufacturer before proceeding**

## 1.1. Meaning of WARNING, CAUTION and NOTE

**WARNING**

**Operating procedures, techniques, etc., which could result in personal injury or loss of life if not carefully followed**

**CAUTION**

Operating procedures, techniques, etc., which could result in damage to equipment if not carefully followed

**NOTE**

Operating procedures, techniques, etc., which is considered essential to emphasize

	<h1 style="color: blue;">MAINTENANCE MANUAL SAVANNAH S</h1>	Doc. No.: MM-SVNH-EN
		Revision: 07
		Rev. Date: 07/11/2022
		Proj. Ref.: SVNH S

## 1.2. Technical documentation

The aircraft approved manuals are the following:

- POH-SVNH: Pilot's Operating Handbook (or Flight Manual) of the Savannah S;
- MM-SVNH: Maintenance Manual of the Savannah S (the present one);
- CM-SVNH: Construction Manual of the Savannah S, kit 1 and kit 2&3 versions;
- SPC-SVNH: Spare Parts Catalogue of the Savannah S;
- Sxxxx: Technical Specification for Savannah S optional installation and description;
- SBxxx: Service Bulletin of ICP (when applicable to Savannah S or specific S/N).

Only the Flight Manual, Maintenance Manual and Spare Parts Catalogue are given with the aircraft, all the rest of information are present and downloadable from I.C.P. Srl aviation website ([www.icp.it](http://www.icp.it)) from My ICP page.

**WARNING**  
**Maintain updated all the aircraft documents at the last approved version present on the I.C.P. Srl website at My ICP page**

## 1.3. Aircraft identification placard

The aircraft is identified by means of Serial Number reported in two different placards: the first one is located in the right side of the fuselage tail, below the stabilizer; the second is made of stainless steel and it is attached to the firewall (starting from A/C delivered in 2022).

A generic Serial Number is composed like this:

yy-mm-54-xxxx

Where *yy* and *mm* corresponds to the *year* and *month* of production, the 54 is the *model* Savannah S and the *xxxx* is the *progressive number*.

## 1.4. Authorized personnel

The Owner of the airplane is the only responsible to make disposition for a correct maintenance of the aircraft and its equipment, by delegating to an approved personnel or organization to carry out the maintenance work. Any questions regarding the maintenance personnel can be sent directly to I.C.P. Srl, writing via email to [info@icp.it](mailto:info@icp.it).

Regarding the equipment installed on the airframe, for example the engine, the propeller or the parachute, are required different authorized personnel in respect of the airframe, the ones prescribed in each relative approved Maintenance Manual of the equipment manufacturer. Always refer to the dedicated manual to find correct information.

	<b>MAINTENANCE MANUAL SAVANNAH S</b>	<b>Doc. No.:</b> MM-SVNH-EN
		<b>Revision:</b> 07
		<b>Rev. Date:</b> 07/11/2022
		<b>Proj. Ref.:</b> SVNH S

**WARNING**

**A maintenance work on airframe and its equipment carried out by not authorized personnel, can lead to a safety problems or death**

**NOTE**

Note for S-LSA (USA) airplane: the maintenance of this airplane must be kept in accordance with the FAA procedures for S-LSA aircraft. Any maintenance or repair on the airplane must be carried out by a FAA Certified / Approved Maintainer or Repairman A&P in accordance with manufacturer maintenance procedure, prescription and Service Bulletin

Certain task of the maintenance herein outlined must be performed by an authorized maintenance organizations or individuals which have the following conditions:

<b>Task type</b>	<b>Required personnel</b>
Daily pre-flight	Owner of the aircraft or Pilot, where basic knowledge of the aircraft and experience in this function has been established
50 [hrs] Scheduled maintenance	Owner of the aircraft only where the National Regulation allows and He has demonstrated sufficient capacity, knowledge and training to perform the work. Also, Maintenance Workshop, Individual authorized and licensed by a National CAA can perform the function or a Person authorized by I.C.P. Srl where possible
All other Scheduled or Unscheduled maintenance, items with time limits	Starting from the 100 [hrs] / 1 year scheduled maintenance, only Maintenance workshop or Individual authorized and licensed by a National CAA and National Dealer of I.C.P. Srl authorized to perform the function where possible
Major Repairs and modifications	National Dealer of I.C.P. Srl or Maintenance workshop authorized directly by the Company to perform each intervention with Its agreement
Engine, Propeller, Other equipment	Authorized by the equipment manufacturer, as indicated in each respective Maintenance Manual and/or Maintenance workshop or Individual authorized and licensed by a National CAA
All the works, excluding equipment	I.C.P. Srl manufacturer workshop

*Table 1: Authorized personnel in function of the maintenance work*

## 1.5. Spare parts purchase

All aircraft structural parts can be purchased only from the manufacturer I.C.P. Srl or the authorized National Dealer. Equipment like Engine, Propeller, rescue parachute or avionics or consumable materials can be purchased directly from the manufacturer I.C.P. Srl or alternatively form the manufacturer of the component itself or from aircrafts parts shop. Any questions can be sent via email to info@icp.it .

	<h1 style="color: blue; margin: 0;">MAINTENANCE MANUAL SAVANNAH S</h1>	Doc. No.: MM-SVNH-EN
		Revision: 07
		Rev. Date: 07/11/2022
		Proj. Ref.: SVNH S

## 1.6. Warranty

The aircraft warranty expires after 12 months starting from the delivery date to the customer. The I.C.P. Srl warranty cover the airframe on each part, excluding the equipment installed. Each equipment is covered by its dedicated warranty politics; always refer to the approved documentation of the manufacturer to find correct information.

For any request under warranty, contact I.C.P. Srl to the phone address or email at info@icp.it .

## 1.7. Maintenance Request Form to ICP manufacturer

The request of a scheduled maintenance, extraordinary maintenance or repair to the manufacturer I.C.P. Srl should be sent via email at info@icp.it with attached the module of *Request of Technical Intervention on the Aircraft*. At the airplane acceptance in ICP factory workshop, the aircraft must be accompanied with the Logbook (or Technical Logbook) or the Maintenance Record pages correctly filled-in and updated to the current state of maintenance of the aircraft. The module of *Request* is attached to the present manual and shown in the *ANNEX A - Request of Technical Intervention on the Aircraft*.

### NOTE

The ICP workshop can not be booked without all the information requested by the dedicated module shown in *ANNEX A - Request of Technical Intervention on the Aircraft*.

An aircraft presented in ICP workshop for maintenance action without the Logbook and equipment Logbook (i.e. the most important the engine Logbook) it is not acceptable

## 1.8. Feedback Form to ICP manufacturer

I.C.P. Srl manufacturer accept a notification of feedback from the owner or maintainer about the aircraft, its documentation, issues, abnormalities identified during the operation or maintenance. The feedback should be sent via email at info@icp.it with attached the module of *Feedback about ICP Aircraft*. This module is attached to the present manual and shown in the *ANNEX B - Feedback about ICP Aircraft*.

### NOTE

The ICP Company can not accept a feedback about the Aircraft without an official email with attached the Feedback Form (previously described) with all the fields properly filled-in

	<h1 style="margin: 0;">MAINTENANCE MANUAL</h1> <h1 style="margin: 0;">SAVANNAH S</h1>	Doc. No.: MM-SVNH-EN
		Revision: 07
		Rev. Date: 07/11/2022
		Proj. Ref.: SVNH S

## 1.9. Aircraft protection and anchoring

*Savannah S<sup>TM</sup>* is an ultra-light metal aircraft almost completely manufactured in Aluminium alloy AL 6061 T6. This AL alloy shows good corrosion resistance features, some simple cleaning operations are nevertheless required. Backwater should be avoided by through drying after water cleaning. Furthermore, high pressure water jets should be avoided in order to prevent any infiltrations in points not easy to inspect or not allowing fast water evaporation.

The original finishing shall remain integer for a long time if the aircraft is periodically washed with a wet sponge and/or car detergent. Always rinse thoroughly and periodically treat with good quality nonabrasive wax. If the aircraft is kept in a salty environment, it must be frequently washed with freshwater and waxed.

Windshield and windows are made of Lexan material, the cleaning should be accomplished with polycarbonate dedicated products. Lexan in contact with solvent, petrol or any other products with even a minimum percentage of alcohol should be avoided and could probably damage immediately or in a short time the part.

The aircraft is not water-proof, rain and humidity can enter from the roof and especially parachute bridles passage (if installed). In case of in-flight rain, maintain Visual Meteorological Condition and possibly perform a route going out of shower.

To protect the aircraft, mainly from rain entering in the cabin, cover the wing and fuselage with a thin water repellent sheet, paying attention to not damage the vortex generators. Before flight open the door and/or fuselage trap door to eventually dry the water or humidity.

To secure the aircraft in case of outside parking, apply the following procedure:

- set parking brakes on;
- alternatively, set minimum two wheels chokes on nose (or tail) wheel;
- lock the control stick with the safety belt, fully backward;
- in case of strong wind forecast or turbulence, anchor the aircraft with tie down kit, connected below the wing strut area, to dedicated attachments;
- if required, additionally anchor to ground the tail from the tail skid and the propeller spacer (not damaging the blades, the spinner, the engine cowling).

The aircraft can be protected also by snow, with the same method above, but a thickness major than 10 [cm] is not allowed and can damage the structure. Remove entirely the snow, remove the cover and let the structure eventually dry before flight or work on the aircraft.

The best practice of course is protect the aircraft inside of a hangar.

## 1.10. Aircraft cleaning

The cleaning of the aircraft can be executed with a wet sponge or microfiber cloth or leather and not with an aggressive/corrosive detergent. The front shield and windows are made of Lexan and the cleaning must be accomplished with polycarbonate dedicated products, not corrosive, without any solvent or alcohol. The contact with fuel and oil can damage instantly this material.

	<b>MAINTENANCE MANUAL SAVANNAH S</b>	<b>Doc. No.:</b> MM-SVNH-EN
		<b>Revision:</b> 07
		<b>Rev. Date:</b> 07/11/2022
		<b>Proj. Ref.:</b> SVNH S

**WARNING**

The contact of any solvent, alcoholic detergent or fuel on the aircraft windows can damage them permanently creating safety problems related to cracks, ruptures, visibility, and transparency. In this case, replace the affected windows

### 1.11. Consumable materials

Type	Name	Note / Use
Engine oil	AeroShell Oil Sport Plus 4 SAE 10 W-40	According to Rotax SI-912-016
Engine coolant	Castrol Antifreeze Anti-Boil	According to Rotax SI-912-016
Brakes oil	Renolit 3000 IT, FIAT Tutela GI/A	Mineral based oil only
General lubrication	WD-40	General lubrication or adhesive cleaning
Grease	White grease, Renolit ZT2	Hinges, bushings, bearings, rotating parts
Spray grease	Bardahl High speed chain	Rotating parts, general additional lubrication
Anti-seize	Copper based anti-seize paste CFG	Landing gear spring fixing bolt-nut
Thread locker	Blue Loctite 243	* see below possible positions
Fuel fitting sealant	Yellow Loctite 577	Seals fuel fittings on tank or junction
Verification green marks	Green Paint Marker	Manufacturer production verifications of bolted connections
Bolt-nut cross-check marks	Cross-check red torque seal	Engine and equipment cross- check bolt-nut marks or other relevant coupling

**Note:** \* possible positions of thread locker: nose landing gear leg, upper plate bolts; brake disc supports; brake caliper inner bolts; bolts on anchor nuts of the front spar fin attachment; parachute and rocket M6 attachments; parachute carabiners; engine hosing to inner mount attachments M10; electric fuel pump attachment bolts; 3 bolts of the wing fuel cup plastic cover on ring; cabin/carburettor heating knob on bowden thread; door gas-spring attachment bolts; fuel tank M6 connection/support bolts

*Table 2: Consumable materials*

	<b>MAINTENANCE MANUAL SAVANNAH S</b>	<b>Doc. No.:</b> MM-SVNH-EN
		<b>Revision:</b> 07
		<b>Rev. Date:</b> 07/11/2022
		<b>Proj. Ref.:</b> SVNH S

### 1.12. Nominal diameters

Item	Diameter [mm]	Tolerance [mm]
3.2mm rivet hole	3.2	0.2
4mm rivet hole	4	0.2
M4 riv-nut hole	6	0.2
AN3 bolt	3/16"=4.8	N/A
AN4 bolt	4/16"=6.4	N/A
AN5 bolt	5/16"=7.9	N/A
AN6 bolt	6/16"=9.5	N/A
AN3 hole	4.9	-0.1/+0.2
AN4 hole	6.5	-0.1/+0.3
AN5 hole	8.0	-0.1/+0.3
AN6 hole	9.6	-0.1/+0.3
Flight Control Surfaces hinge line, bushing internal diameter	4.9	0.1
FCS hinge line, bushing external diameter	5.9	+/-0.1
FCS hinge line, horn hole for bushing	6.0	0.2

Table 3: Nominal diameters

### 1.13. Tightening torques

Standard application		
Screw size	Torque [Nm]	Tolerance [Nm]
AN3	6	+/-0.5
AN4	15	+/-1
AN5	20	+/-1.5
AN6	30	+/-2
AN7	45	+/-2
AN8	65	+/-2
M5	6	+/-0.5
M6	13	+/-1
M8	25	+/-1.5
M10	40	+/-2

Table 4: Tightening torques for standard application





# MAINTENANCE MANUAL SAVANNAH S

<b>Doc. No.:</b>	MM-SVNH-EN
<b>Revision:</b>	07
<b>Rev. Date:</b>	07/11/2022
<b>Proj. Ref.:</b>	SVNH S

<b>Unusual application</b>			
<b>Part</b>	<b>Screw id</b>	<b>Torque [Nm]</b>	<b>Tolerance [Nm]</b>
Upper fork of the rear wing strut (rear strut assembly)	AN4	6.5	+0/-0.5
Flight control system bolt crossing the uniball	AN5	16	+/-0.5
Flight control system uniball nut on rod	M8	10	+5/-0
Trim tab uniball crossing bolt	AN3	6	+/-0.5
Trim tab uniball counter-nut on rod	M5	6	+/-0.5
Trim tab actuator lever connection to uniball and rod	M3	Touching + as required	Prevent damage of actuator lever
Flight control system self-locking nut joints (not rotating bolt)	AN3	6	Allows rotation without axial and radial free play
Flight control system castle nut joints	AN3 / AN4 / AN5	Touching - as required for teeth alignment for pin	Allows rotation without axial and radial free play
Flight control surfaces hinges	AN3	Touching - as required for teeth alignment for pin	Allows rotation without axial and radial free play
Nonio tender bolt	AN3	6	+/-0.5
Pulley axis bolt	AN3	Touching - as required for teeth alignment for pin	Allows rotation without axial and radial free play
Torque tube rear horn (roll)	AN3	Touching + as required to lock	Prevent tube ovalization
Flaperon mixer horns (roll)	AN3	Touching + as required to lock	Prevent tube ovalization
Flaperon mixer hinges	AN5	Touching	Allows rotation
Rudder pedals plastic hinges bushing	AN3	Touching + as required to allows pedals rotation	Not excessive friction in the pedals rotation
Spacer to engine flange	M8	25	+/-1.5
Wheel hub bearing ring nut	M17	Close up to the wheel is not easily rotating by hand	Not excessive friction to the wheel rotation
Main wheel hub axle ring nut	M24	60	+10/-0
Nose wheel hub axle ring nut	M17	Close up to the wheel is not easily rotating by hand	Not excessive friction to the wheel rotation
Wheel rim assembly (ICP production)	AN4	15	+/-1
Wheel rim assembly	M8	15	+/-1

Table 5a



# MAINTENANCE MANUAL SAVANNAH S

<b>Doc. No.:</b>	MM-SVNH-EN
<b>Revision:</b>	07
<b>Rev. Date:</b>	07/11/2022
<b>Proj. Ref.:</b>	SVNH S

<b>Unusual application</b>			
<b>Part</b>	<b>Screw id</b>	<b>Torque [Nm]</b>	<b>Tolerance [Nm]</b>
Wheel disc supports on rim	M5	8	+2/-0
Wheel disc	M6	10	+2/-0
Main landing gear spring lower constrain flange, vertical attachment bolts / stop nuts	M8	Close up to the spring is completely constrained in the channel against red vulcolan rubber	Not excessive, prevent nut and fuselage damage, not more than 20 [Nm]
Nose wheel hub bolt on fork (round head, hexagonal wrench)	M8	20	+/-1.5
For Tail Dragger configuration (if applicable), front horn to connect the steering pedal rods, torque of bushing	AN4	Touching	Not excessive friction, the horn can rotate
Brake caliper outer bolts/nuts	M6	15	+/-1
Brake caliper inner bolts	M6	10	+/-1
Engine mount internal ring on engine housing	M10	40	+/-2
Engine mount silent block	AN5	20	+/-1.5
Fuel metal clamp	N/A	Maximum possible screw closure	Not excessive, prevent hose cutting
Fuel shut-off valve fittings	N/A	Touching + 1/4 turn	Not excessive, prevent only fuel loosing
Tank fitting and drain valve 1/4"	N/A	Touching + 1/4 turn	Not excessive, prevent only fuel loosing
Collector tank reserve probe M16	N/A	Touching + 1/4 turn	Not excessive, prevent only fuel loosing
Tank anchoring points	M6	8	+2/-1
Oil line metal clamp	N/A	Maximum possible screw closure	Not excessive, prevent hose cutting
Fitting on oil tank	N/A	25	+0/-2
Drain screw of oil tank	M12	25	+0/-2
Fitting on oil radiator	N/A	20	+5/-0
Engine oil pump fittings	M18	25	+/-1.5
Engine crankcase oil banjo bolt	M6	10	+/-0.5
Magnetic plug	N/A	25	+0/-2
Engine oil filter	N/A	Touching +3/4 turn	N/A
Engine water pump bolts	M6	10	+/-0.5

Table 5b

	<b>MAINTENANCE MANUAL SAVANNAH S</b>	<b>Doc. No.:</b> MM-SVNH-EN
		<b>Revision:</b> 07
		<b>Rev. Date:</b> 07/11/2022
		<b>Proj. Ref.:</b> SVNH S

<b>Unusual application</b>			
<b>Part</b>	<b>Screw id</b>	<b>Torque [Nm]</b>	<b>Tolerance [Nm]</b>
Cooling line metal clamp	N/A	Maximum possible screw closure	Not excessive, prevent hose cutting
Radiators supports	M10	30	+10/-5
Radiators silent block	M6	13	+/-1
Airbox supports	M6	13	+/-1
Metal clamp fuel system	N/A	Maximum possible screw closure	Not excessive, prevent hose cutting
Metal clamp (general)	N/A	Strong screw closure	Fix the pipe, prevent hose excessive compression
Norma metal clamp	M6	Surfaces of clamp touching or if possible 13	Prevent compression of inner pipe
Terminals for engine electric wirings (starter motor, starter relay)	M6	4	+1/-0
Exhaust collectors on cylinder (bent flange)	M8	15	Attention, leave a minimum of 1 screw thread free after the nut
Exhaust terminal collar	N/A	Max possible closure	N/A

*Table 5c (a-c): Tightening torques for unusual application*

## 1.14. Safetying practices

Any time a self-locking nut and/or split pin is removed for inspection, such part(s) should be replaced with a spare new one before reassembling.

### 1.14.1. Safety wires

Install the safety wire tight in sense of preventing the unscrewing rotation of the nut or element. The safety wire is considered correctly installed if it is really tight and all the parts with double wire are turned constantly.



# MAINTENANCE MANUAL SAVANNAH S

Doc. No.: MM-SVNH-EN

Revision: 07

Rev. Date: 07/11/2022

Proj. Ref.: SVNH S

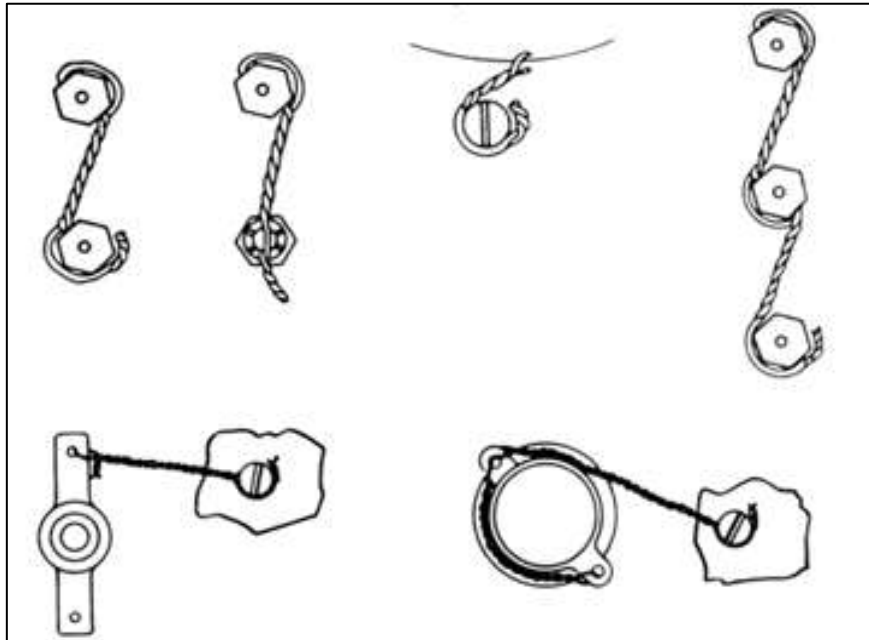

Figure 1: Safety wires example

Always replace the safety wire with a new one, when the bolt or nut has been opened.

## 1.14.2. Castle nut and cotter pin

There are two different method to install the cotter pin on the castle nut (*Figure 2*): the first one with cotter pin oriented vertically and the other one horizontally in respect of the nut cutting. In both cases, the cotter pin is considered properly installed if it is tight, not moving, the loop is not deformed and constrained. The free edges of the pin must touch the bolt, constrain the pin itself and not touch the surrounding structure. In case of vertical pin orientation, the loop is within the nut cutting, instead the horizontal pin orientation must have the loop outside the castle nut cutting.



Figure 2: Cotter pin example

Always replace the cotter pin with a new one, when the bolt or nut has been opened.  
The cotter pin size must be correctly coupled with the castle nut, as shown in the *Table 6* below.



# MAINTENANCE MANUAL SAVANNAH S

Doc. No.: MM-SVNH-EN

Revision: 07

Rev. Date: 07/11/2022

Proj. Ref.: SVNH S

**AN380 (MS24665) – COTTER PIN**

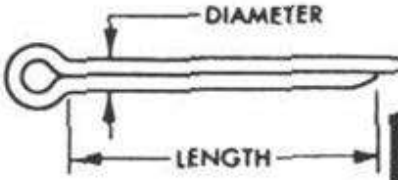

		CORROSION RESISTING STEEL		DIAMETER & LENGTH	CADMIUM PLATED STEEL	
		MS24665	AN380		MS24665	AN380
		-20	C1-1	1/32 x 3/8	-3	-1-1
		-22	C1-2	1/32 x 1/2	-5	-1-2
		-24	C1-3	1/32 x 3/4	-7	-1-3
		-26	C1-4	1/32 x 1	-9	-1-4
		-149	C2-1	1/16 x 3/8	-130	-2-1
		-151	C2-2	1/16 x 1/2	-132	-2-2
		-153	C2-3	1/16 x 3/4	-134	-2-3
		-155	C2-4	1/16 x 1	-136	-2-4
		-157	C2-5	1/16 x 1-1/4	-138	-2-5
		-159	C2-6	1/16 x 1-1/2	-140	-2-6
		-161	C2-7	1/16 x 1-3/4	-142	-2-7
		-162	C2-8	1/16 x 2	-143	-2-8
		-229		5/64 x 3/4		
		-231		5/64 x 1		
		-298	C3-2	3/32 x 1/2	-281	-3-2
		-300	C3-3	3/32 x 3/4	-283	-3-3
		-302	C3-4	3/32 x 1	-285	-3-4
		-304	C3-5	3/32 x 1-1/4	-287	-3-5
		-306	C3-6	3/32 x 1-1/2	-289	-3-6
		-308	C3-7	3/32 x 1-3/4	-291	-3-7
		-309	C3-8	3/32 x 2	-292	-3-8
		-366	C4-2	1/8 x 1/2	-349	-4-2
		-368	C4-3	1/8 x 3/4	-351	-4-3
		-370	C4-4	1/8 x 1	-353	-4-4
		-374	C4-6	1/8 x 1-1/2	-357	-4-6
		-377	C4-8	1/8 x 2	-360	-4-8
		-379	C4-10	1/8 x 2-1/2	-362	-4-10
				5/32 x 1	-419	-5-4
				5/32 x 1-1/2	-423	-5-6
				5/32 x 2-1/4	-427	-5-9
			C5-9			

DASH NO.	DIAMETER AND THREAD	COTTER PINS FOR AN310 & AN320
-3	#10-32	AN380-2-1
-4	1/4-28	AN380-2-2
-5	5/16-24	AN380-2-2
-6	3/8-24	AN380-3-3
-7	7/16-20	AN380-3-3
-8	1/2-20	AN380-3-3
-9	9/16-18	AN380-4-4
-10	5/8-18	AN380-4-4
-12	3/4-16	AN380-4-5

Table 6: Cotter pin coupling with castle nut

### 1.14.3. Threaded fasteners

The fasteners must be adequate to the hole, not ovalized, and depth of the structure and or not vibrating. The head of bolt must be set in contact to the structure and closed with a nut at proper torque, depending on the application (see Table 16) and size. The thickness of the connection must be lower than the bolt length, plus minimum one washer on the nut side and minimum two free thread pitches over the nut end. If the bolt is longer than required, add required number of washers to respect the correct installation. The fasteners is normally closed by holding the head of the bolt and rotating the nut only; in few cases the closing procedure is inverted, by rotating the bolt, for space reasons only.

Replace the bolt with a new one when it is damaged or consumed in any parts. Replace always the stop nut when removed and eventually the bolt. Replace also the stop nut when it is older than 20 years.



# MAINTENANCE MANUAL SAVANNAH S

Doc. No.:	MM-SVNH-EN
Revision:	07
Rev. Date:	07/11/2022
Proj. Ref.:	SVNH S

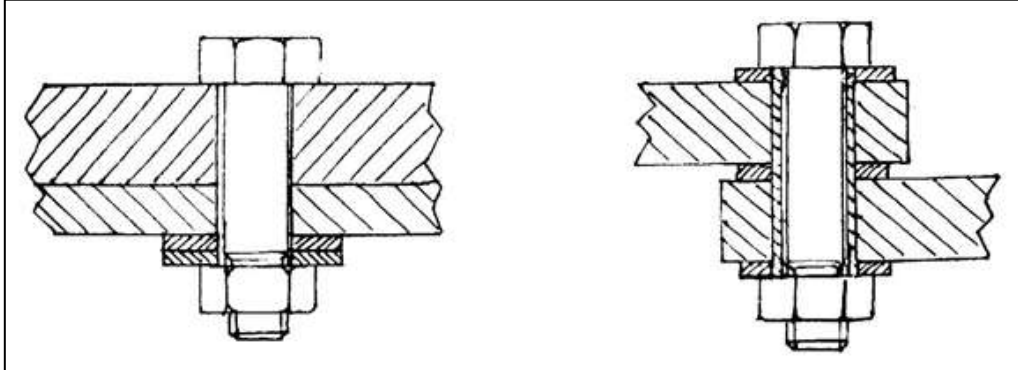

Figure 3: Threaded fasteners

#### 1.14.4. Bolt-Nut cross-check mark

Green marks are usually sign of manufacturer production verification and should not be used as a rotation visual cross-check marks.

Cross-check red torque seal (glue) can be used in engine parts or important threaded fastening to monitor visually the unscrewing. The cross-check must be marked parallel to the screw axis and perpendicular to the touching faces of the fastening parts and eventually the structure. When the cross-check mark is consumed, damaged or cracked, replace the nut (and eventually the bolt) with a new one and close at proper torque.

#### 1.14.5. Pop riveting

Assemble the most part of structure by means of Cleco (spring loaded clamp), installed respectively in the proper holes diameter (usually 2.5, 3.2 and 4 [mm]). Remove a Cleco and add the rivet, chosen correspondent with the hole diameter, and with a proper length exceeding the sheet of almost 1.5 times the rivet diameter, excluding the ones described differently in the *Construction Manual*. Pull the rivet properly and repeat the operation. Always control the result of the special riveting process: check the head of rivet is pressing entirely and parallel to the skin, not damaged, check the bulb of the rivet (behind), it must be strongly pressing the sheets and the bulb dimensions must be minimum: height 0.75 times the diameter, width 1.3 times the diameter.

#### 1.14.6. Solid riveting

Assemble the most part of structure by means of Cleco, installed respectively in the proper holes diameter (usually 2.5, 3.2 or 4 [mm]). Remove a Cleco and add the solid rivet, chosen correspondent with the hole diameter, and with a proper length exceeding the sheet of almost 1.5 times the solid rivet diameter. Press the rivet properly and repeat the operation. Always control the result of the special riveting process: check the head of rivet is pressing entirely and parallel to the skin, not damaged, check the blind side of rivet, the bulb head, it must be strongly pressing the sheets and

	<b>MAINTENANCE MANUAL SAVANNAH S</b>	Doc. No.:	MM-SVNH-EN
		Revision:	07
		Rev. Date:	07/11/2022
		Proj. Ref.:	SVNH S

the bulb dimensions must be: minimum height of 0.5 times the diameter, minimum width of 1.5 times the diameter.

#### 1.14.7. Cable nonio tender

The Nonio cable tender is a double stainless steel plate which allows to regulate the cable tension by changing the holes alignment, with a step-by-step pitch variation of 0.4 [mm]. A bolt with stop nut is installed and closed to fix the selected length. When changed the cable tension, always control the wear of the nonio eyelets and the closure of the stop nut.

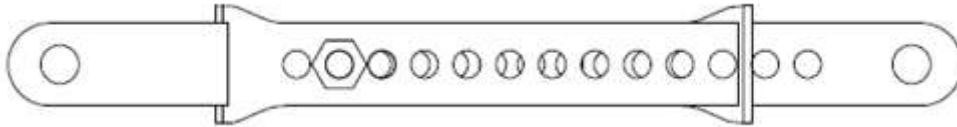

Figure 4: Nonio cable tender

#### 1.14.8. Hose assembly

Hereafter are shown some pictures of rubber hoses installation and normal closure of the metallic clamp. The free edge of the rubber must fit correctly on the corrugated pipe (or straight type), the rubber must not be consumed, cut or cracked. The metal clamp must seal and lock the hose and the pipe respectively and the side of the metal clamp must not cut the rubber.



Figure 5: Fuel hose on fitting



# MAINTENANCE MANUAL SAVANNAH S

Doc. No.:	MM-SVNH-EN
Revision:	07
Rev. Date:	07/11/2022
Proj. Ref.:	SVNH S



Figure 6: Fuel hose on corrugated pipe



Figure 7: Oil hose on corrugated pipe



Figure 8: Water hose on corrugated pipe



	<b>MAINTENANCE MANUAL SAVANNAH S</b>	<b>Doc. No.:</b> MM-SVNH-EN
		<b>Revision:</b> 07
		<b>Rev. Date:</b> 07/11/2022
		<b>Proj. Ref.:</b> SVNH S

## 1.15. Tools

The following sections highlight some tools required for the aircraft maintenance. Some special tool are part of the maintenance workshop equipment.

### 1.15.1. Standard maintenance tools

Tool	Main application
Common screw driver	Several, metallic hose clamp
Crosspoint screw driver	Several
Metric fixed wrench	Metric nuts closure
Metric socket wrench	Metric nuts closure
Inches fixed wrench	Inches nuts closure
Inches socket wrench	Inches nuts closure
Torque wrench	All bolt/nut to be closed and verified at torque
Allen key	Inspection panel opening or other
Cutter	Several
Pliers	Several
Grip pliers	Several
Safety wire twister	Safety wiring
Air compressor with manometer	Structures
Oil filter wrench	Rotax engine oil filter
4 tooth lockring spanner 24mm (M17)	Nose landing gear axle lock ring (M17)
4 tooth lockring spanner 32mm (M24)	Landing gear axle lock ring (M24)

Table 7: Standard tools

### 1.15.2. Unusual maintenance tools

Tool	Main application
Driller (and drill bits)	Several
Cleco pliers (and clecoes)	Cleco for 2.5, 3.2, 4 [mm] rivets
Rivet gun	Install rivets
Solid rivet squeezers	Install solid rivets
Nicopress swage	Close nicopress on control cables
Heat gun	Thermal restringing sleeve
Wire cutters	Electric wires
Crimping tools pliers	Electric Faston and connectors pliers to crimp
Seeger pliers	Install / remove seeger
Hand snips	Cut sheets
Hand file	Clean and round sheets corner / angle
Sandpaper	Clean and round sheets corner / angle

Table 8: Unusual tools

	<b>MAINTENANCE MANUAL SAVANNAH S</b>	<b>Doc. No.:</b> MM-SVNH-EN
		<b>Revision:</b> 07
		<b>Rev. Date:</b> 07/11/2022
		<b>Proj. Ref.:</b> SVNH S

### 1.15.3. Auxiliary tools (part of the aircraft kit)

Tool	Main application
Flaperon jig code SA200VG	Set the Flaperon at the neutral position
Tank cup key	Key to open the wing tank cups

Table 9: Auxiliary tools

### 1.15.4. Measuring tools

Tool	Main application
Calibre	Small measures and inner hole diameter
Line centimeter	Major measures
Hand monometer	Tyre pressure
Torque wrench	Close or measure bolt / nut torque
Cable tensiometer	Control cable tension
Digital spirit level bubble (with 0.1° resolution)	Measure level angles (not for horizontal angle)

Table 10: Measuring tools

## 1.16. Terms and Definitions

The following list of terms is relative to the maintenance tanks to apply.

Term	Definition
Flight hours	Sum of the entire period between the take-off and landing of the aircraft
Operating hours	Sum of the entire period between the system is active (i.e. the powerplant is rotating, mainly)
Time limit	Life cycle or period when to replace the system or parts, even if the components seem good
Overhaul	Complete revision of the system, generally executed by the equipment manufacturer
Verify	Visual verification and evaluation that the system or the parts is in a good state or correct shape, compliant to the original construction or assembly, without corrosion or cracks or any problems
Check	Manual operation and observation of the parts, travel, correct operation, bolt closure, evaluation that the system and parts or assembly are functioning properly, in a good operative state

Table 11: Terms and Definitions

	<b>MAINTENANCE MANUAL SAVANNAH S</b>	<b>Doc. No.:</b> MM-SVNH-EN
		<b>Revision:</b> 07
		<b>Rev. Date:</b> 07/11/2022
		<b>Proj. Ref.:</b> SVNH S

### 1.17. Airworthiness Limitations

The airworthiness limitations *Chapter 1.17* is issued by the ICP Manufacturer and approved by the Aviation Authority (i.e. EASA or FAA) in case of Certified Aircraft only, in accordance to the criterion given in the *Part-21*, requirement *21A.31(a)3.* and *FAR 33.4.* .

There are no particular airworthiness limitations of the aircraft described within the present Maintenance Manual, except the ones reported in the dedicated section of the approved Aircraft Flight Manual (POH-SVNH). If the present Maintenance Manual (MM-SVNH) is not respected, followed and applied in any descriptions, timing (included tolerances) and practices, the continuous airworthiness of the aircraft is considered not ensured. The consequence is the not operability of the aircraft. Exception can be made in case of ferry flight to the maintenance workshop, with the application of certain operational limitations and operator authorization that can be defined case by case in agreement with the ICP Manufacturer and the Aviation Authority in case of Certified Aircraft.

### 1.18. Maintenance interval tolerances

The maintenance work can be executed with a tolerance of +/-5 Operating Hours or +/-1 month (where applicable), which one is shorter, in respect of the schedule. Regarding items subject of time limits, the tolerance is 5% of the time or 6 month, which one is minor.

### 1.19. Aircraft lifting

There are many possibility to lift up the aircraft; the only important concept is to distribute the pressure around the touching point and to press only in structurally rigid areas. Follows some examples:

- First point: fuselage rear cone lower skin, with a minimum distribution between two consecutive bulkhead in the total fuselage width; second point: fuselage cabin area lower skin, with a minimum distribution between the two lower longitudinal stringers and entire width of nose; third point: if required below the wing skin to balance the rotation.
- First point: left wing lower skin, minimum distribution between the two last ribs plus front and rear spar; second point: the symmetrical on right wing; third point: the tail skid or eventually the nose, distributing the pressure, to balance the rotation.
- First point: attachments of the main landing gear; second point: nose of the fuselage, with a minimum distribution between the two lower longitudinal stringers in the firewall area (paying attention to fuel pipe).
- First point: main landing gear wheels; second point: nose landing gear wheel.
- In case of wing disassembled: four attachments of the wing, in the cabin frame and eventually balance the rotation with a tail skid point.
- If aircraft equipped with hooks on the cabin frame: first points from the hooks; second point from the rear fuselage, with a large belt/strip (preventing damages) passed around the fuselage tail cone, in front of the stabilizer area.

	<h1 style="margin: 0;">MAINTENANCE MANUAL</h1> <h2 style="margin: 0;">SAVANNAH S</h2>	Doc. No.: MM-SVNH-EN
		Revision: 07
		Rev. Date: 07/11/2022
		Proj. Ref.: SVNH S

### 1.19.1. Engine lifting

The engine can be lifted up from the intake aluminium manifold pipes, where is present a dedicated ring. Always refer to the approved engine manufacturer manuals to execute operations on powerplant.

### 1.20. Aircraft Levelling

The aircraft is levelled when the fuselage cone upper skin, just behind the wing rear attachments, is set horizontal, both longitudinally and transversally.

### 1.21. Aircraft weighing

The aircraft can be weighed by lifting on a multiple points described in the *Chapter 1.19* or simply from the three wheels, with scales.

When needed to calculate the aircraft Weight and Center of Gravity, apply the following procedure:

- Level the aircraft (ref. *Chapter 1.20*);
- Zeroing of the scales;
- Place the aircraft on three scales, one for each wheel;
- Take note of the weights indicated by the scales;
- Apply the calibration delta to the values, if present a calibration table of the scales;
- Vertically project with a plumb line the wing leading edge position on the floor, then measure from this point the distance of the nose gear  $D_F$  and the distance of the main landing gear  $D_R$ ;
- Alternatively, apply design values of these Distances, only if the airplane has been correctly levelled according to *Chapter 1.20*:  $D_F=0.825$  [m],  $D_R=0.691$  [m]. For tail dragger aircraft configuration the tail is  $D_F=-4.373$  [m] and main wheels are  $D_R=0.163$  [m].
- Use the following formula to calculate the resulting weight and longitudinal center of gravity:

$$W_{TOT} = W_F + W_{R\ RX} + W_{R\ LX} \text{ [kg]}$$

$$X_{CG} = \frac{(W_{R\ RX} + W_{R\ LX}) \cdot D_R - W_F \cdot D_F}{W_F + W_{R\ RX} + W_{R\ LX}} \text{ [m]}$$

$$X_{CG}(\% \text{ MAC}) = \frac{X_{CG} \cdot 100}{MAC} = \frac{X_{CG} \cdot 100}{1.32}$$

	<b>MAINTENANCE MANUAL SAVANNAH S</b>	<b>Doc. No.:</b> MM-SVNH-EN
		<b>Revision:</b> 07
		<b>Rev. Date:</b> 07/11/2022
		<b>Proj. Ref.:</b> SVNH S

**NOTE**

The weighing method described calculates the weight and CG of the aircraft in the condition set on the scales, including fuel and other object on board. To calculate the Empty Operative Weight, drain entirely the fuel and remove all equipment and object not part of the aircraft

## 1.22. Fuel and fluids draining

Fuel draining can be executed from collector tank sediment bowl, with purge valve, located below the fuselage, behind the main landing gear. To remove almost all the not usable fuel, incline the aircraft backward, touching the tail skid on ground, and drain from the same point after a normal purge.

To drain the oil brakes, open the bleeding screw on the lower side of brake caliper and then add pressure from the top brake pump (unscrew to open the pump embodied tank) by means of air compressor.

The engine oil draining can be executed by opening the lower screw of the oil tank. Further details are described in the approved manufacturer maintenance manual.

To drain the coolant from engine system is needed to apply the procedure described by the engine manufacturer maintenance manual.

## 1.23. Tires pressure setting

Tyre size	Aircraft take-off weight [kg]	Pressure [bar]
4"	450	2.2 +/- 0.2
	600	2.5 +/- 0.2
6"	450	2.0 +/- 0.2
	600	2.2 +/- 0.2
Tundra	450	1.5 +/- 0.2
	600	2.0 +/- 0.2
8" tail	600	2.5 +/- 0.2

*Table 12: Tires pressure*

	<b>MAINTENANCE MANUAL SAVANNAH S</b>	<b>Doc. No.:</b> MM-SVNH-EN
		<b>Revision:</b> 07
		<b>Rev. Date:</b> 07/11/2022
		<b>Proj. Ref.:</b> SVNH S

#### 1.24. Aircraft approved documentation

Name	Description	Code
Savannah_S_POH_EN_RevXX	Savannah S Pilot's Operating Handbook	POH-SVNH-EN
Savannah_S_POH_TDaddendum_EN_RevXX	Savannah S Tail Dragger Pilot's Operating Handbook	POH-SVNH-TD-EN
Savannah_S_MM_EN_RevXX	Savannah S Maintenance Manual (the present manual)	MM-SVNH-EN
Savannah_S_Construction Manual-RevXX	Savannah S Construction Manual	CM-SVNH-EN
Savannah_S_Spare Parts Catalogue-RevXX	Savannah S Spare Parts Catalogue	SPC-SVNH-EN
Sxxxx-...name...-RevXX	Savannah S Technical Specification number xxx ...name...	Sxxxx
SBxxx	Service Bulletin number xxx	SBxxx

Table 13: Approved documents

**WARNING**  
Periodically updates the airplane approved documentation by monitoring and downloading the new file revisions in the I.C.P. Srl aviation website [www.icpaviazione.it](http://www.icpaviazione.it) at My I.C.P. page, after requesting login credentials

The airplane Flight Manual and the Maintenance Manual are issued according to the requirements of the CS-VLA Amdt.1, ASTM F2245-16c, ASTM F2746-14 and ASTM F2483-18e1 (particularly Ch. 5.1.).

#### 1.25. Unit conversions

Unit 1		Unit 2	
in	1	mm	25.4
kg	1	lbs	0.454
Nm	1	ft lbs	0.738

Table 14: Conversions



# MAINTENANCE MANUAL SAVANNAH S

Doc. No.: MM-SVNH-EN

Revision: 07

Rev. Date: 07/11/2022

Proj. Ref.: SVNH S

## 2. Daily Pre-Flight Check

### NOTE

The Daily pre-flight check is in charge of the pilot who execute the first flight of the day and consist substantially in a normal pre-flight verification around the aircraft. The list can be shorten if consecutive flight are executed. The same checks are reported in the Flight Manual (Pilot's Operating Handbook) of the aircraft.

### CAUTION

Performing the check around the aircraft, pay particular attention to deformation, cracks, bolts not tight, absent safety wires or cotter pins, abnormal parts or shapes, excessive free play or parts loosing, lubrication, abnormal leaking.

### CAUTION

To perform each maintenance task or verification procedure related to the engine and propeller or additional equipment must be follow the relevant approved Operator or Maintenance Manual of the manufacturer of that system.

For the Terms used, apply the Definitions of *Chapter 1.16*.

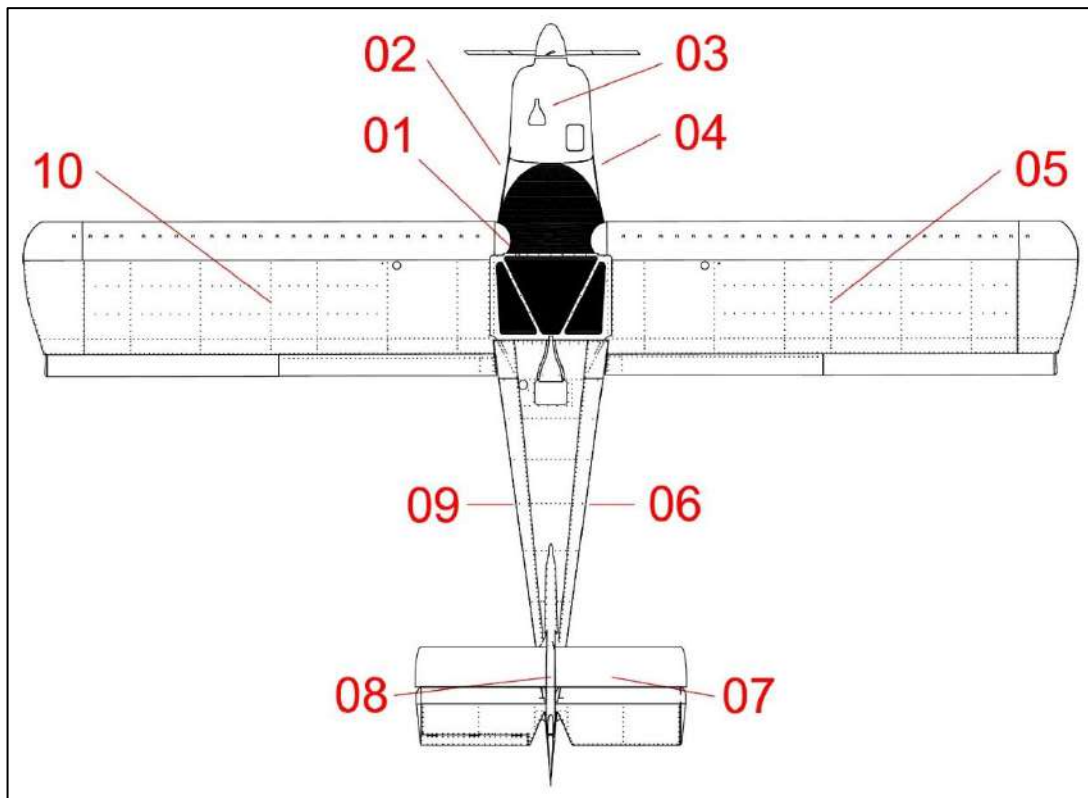

Figure 9: Daily pre-flight check sequence plan view



# MAINTENANCE MANUAL SAVANNAH S

<b>Doc. No.:</b>	MM-SVNH-EN
<b>Revision:</b>	07
<b>Rev. Date:</b>	07/11/2022
<b>Proj. Ref.:</b>	SVNH S

Area	N°	Action
Cabin	01.01	Fuel purge from Collector tank valve; verify water and deposits, remove if any
	01.02	Magnetos switch OFF
	01.03	Master switch OFF, then activate when needed for next checks
	01.04	Control stick check free and smooth around the entire travels pitch and roll
		Verify control stick free play within tolerances and cotter pins presence and correct installation
	01.05	Verify rudder pedals hinges
	01.06	Verify rudder pedals and cables cotter pins presence and correct installation
	01.07	Remove any possible object or foreign part that can obstacle the control stick and rudder pedals and their cinematics
	01.08	Flap control and indication (if electric) moving in the entire run and fixed in each relevant position. Both Flaperon surface moving downward or upward coherently
	01.09	Check Trim control moving in the entire run when pressing its relative button or switch and monitor the indicator coherently
	01.10	Check Collector tank red reserve warning indication turn on when pressing test button
	01.11	Light switches on and verify externally stroboscopic and navigation light
	01.12	Master switch OFF when checks of electrical items completed
	01.13	Throttle control smooth around the entire travels. Set to idle
	01.14	Carburetor heating knob check, remains open when activated then set closed
	01.15	Seats belts and harnesses check good state of latches, closure and attachments
	01.16	Baggage latches (if any) check good state and attachments
	01.17	Aircraft floor cleaning in the area of rudder pedals, cleaning of the primary and engine instruments
	01.18	Check brake pumps without excessive oil leakage
	01.19	Verify cabin frame forward attachments to wing
	01.20	Verify cabin frame rearward attachments to wing
	01.21	Fuel shut-off valve, verify safety wire locking in the open position
01.22	Fuel connection between wings and fuselage: verify hoses and T junction	
Front fuselage left side	02.01	Verify door closing properly, with external handle
	02.02	Verify external skin correct shape and rivets
	02.03	Verify main landing gear attachments to fuselage and red rubber (vulcolan) position
	02.04	Verify wheel axle with teeth washer closed
	02.05	Verify brake caliper installed and no leakage
	02.06	Verify brake pipe properly supported and undamaged
	02.07	Verify wheel fairing rigid (if installed)
	02.08	Verify tyre pressure if visually flat





# MAINTENANCE MANUAL SAVANNAH S

<b>Doc. No.:</b>	MM-SVNH-EN
<b>Revision:</b>	07
<b>Rev. Date:</b>	07/11/2022
<b>Proj. Ref.:</b>	SVNH S

Area	N°	Action
Powerplant area	03.01	Remove engine cowling top
	03.02	Verify oil system: damages, loosing, supports, leakages of lines, hoses, radiator, tank
	03.03	Check oil level by means of dipstick indication. Before, check both magneto switches are OFF, make rotating the propeller by hand (right turn from pilot view) until hearing gurgle from the oil tank. If necessary add oil
	03.04	Verify coolant system: damages, loosing, supports, leakages of lines, hoses, radiator, tank
	03.05	Verify coolant level
	03.06	Verify airbox and induction valve (carburetor heating) correct installation
	03.07	Verify carburetors attachments and connection to airbox
	03.08	Verify exhaust system integrity, rigidity and manifold springs
	03.09	Verify fuel system: hoses, metal clamp closed, no leaking, fuel filters visually clear, no wear or rubbing of the pipes
	03.10	Propeller blades and leading edge integrity
	03.11	Spinner rigidity and integrity
		Verify nose landing gear, bungee and wheel fork integrity
		Verify nose wheel axle safety wires
	03.12	Verify nose wheel fairing rigid (if installed)
	03.13	Verify plastic bushing guide correct position and free play within tolerance
	03.14	Verify top plate of nose landing gear leg, present and fixed
	03.15	Verify tyre pressure if visually flat
03.16	Install engine cowling top	
03.17	Verify the engine cowling is rigid and all DZUS closed	
Front fuselage right side	04.01	Verify door closing properly, with external handle
	04.02	Verify external skin correct shape and rivets
		Verify main landing gear attachments to fuselage and red rubber (vulcolan) position
	04.03	Verify wheel axle with teeth washer closed
	04.04	Verify brake caliper installed and no leakage
	04.05	Verify brake pipe properly supported and undamaged
	04.06	Verify wheel fairing rigid (if installed)
04.07	Verify tyre pressure if visually flat	
Right wing	05.01	Verify wing struts are straight and correct shape
	05.02	Verify wing struts lower attachments, bolt and nut presence and general integrity
	05.03	Verify wing struts upper attachments, bolt and nut presence and general integrity
	05.04	Verify jury strut integrity and rigidity
	05.05	Verify all vortex presence
	05.06	Verify external skin correct shape and rivets
	05.07	Check fuel tank cup closed and vent connected



# MAINTENANCE MANUAL SAVANNAH S

<b>Doc. No.:</b>	MM-SVNH-EN
<b>Revision:</b>	07
<b>Rev. Date:</b>	07/11/2022
<b>Proj. Ref.:</b>	SVNH S

Area	N°	Action
Right wing	05.08	Verify fuel vent pipe free
	05.09	Verify wing tip light rigidity (if present)
	05.10	Check flaperon correct operation and excursion
	05.11	Check flaperon hinge cotter pins and bushing free play
	05.12	Verify flaperon support horns
	05.13	Verify flaperon skin correct shape and rivets
Rear fuselage right side	06.01	Verify external skin correct shape and rivets
	06.02	Verify lower trap door closed
	06.03	Verify antennas rigid (if present)
	06.04	Verify tail skid integrity
Horizontal tail	07.01	Verify stabilizer and elevator skins correct shape and rivets
	07.02	Verify stabilizer attachments
	07.03	Verify tip covers
	07.04	Verify trim tab structure and control lever rigidity, push-pull bar straight
	07.05	Check elevator correct operation and excursion
	07.06	Check elevator hinge cotter pins and bushing free play
Vertical tail	08.01	Verify antiskid, fin and rudder skins correct shape and rivets
	08.02	Verify fin attachments
	08.03	Verify fin and rudder tip covers
	08.04	Check rudder correct operation and excursion
	08.05	Check rudder hinge cotter pins and bushing free play
Rear fuselage left side	09.01	Verify external skin correct shape and rivets
	09.02	Verify side inspection port closed
	09.03	Verify parachute extraction area closed and central bridle cover rigid (if installed)
Left wing	10.01	Verify external skin correct shape and rivets
	10.02	Verify flaperon skin correct shape and rivets
	10.03	Check flaperon correct operation and excursion
	10.04	Check flaperon hinge cotter pins and bushing free play
	10.05	Verify flaperon support horns
	10.06	Verify wing tip light rigidity (if present)
	10.07	Verify all vortex presence
	10.08	Check fuel tank cup closed and vent connected
	10.09	Verify fuel vent pipe free
	10.10	Pitot tube straight and aligned to wing lower skin, hole free
	10.11	Verify wing struts are straight and correct shape
	10.12	Verify wing struts lower attachments, bolt and nut presence and general integrity
	10.13	Verify wing struts upper attachments, bolt and nut presence and general integrity
	10.14	Verify jury strut integrity and rigidity

*Table 15: Daily pre-flight check list*



# MAINTENANCE MANUAL SAVANNAH S

<b>Doc. No.:</b>	MM-SVNH-EN
<b>Revision:</b>	07
<b>Rev. Date:</b>	07/11/2022
<b>Proj. Ref.:</b>	SVNH S

## 3. Time limits

When the part reported in the following table reach the time limit (marked with the x), it must be replaced or dedicated maintenance performed.

### NOTE

For each parts or systems listed in the following table are also prescribed scheduled maintenance that must be executed during the flying hours or the aircraft. If the part/system maintenance is already performed, do not apply the present time limit of replacement

System / part	Time limit [year]				
	1	5	6	10	20
Wing attachment bolts and stop nuts				X	
Tailplane attachment bolts and stop nuts				X	
Fuel system rubber hoses		X			
Fuel filters		X			
Fuel vent pipes		X			
Electric fuel pump				X	
Fuel sediment bowl valve o-ring (on collector tank bottom)					X
Fuel cup support ring on wing fuel tank o-ring					X
Fuel fitting on fuel tanks o-ring					X
Oil system rubber hoses		X			
Oil radiator silent block				X	
Engine oil and filter	X*				
Cooling system rubber hoses		X			
Cooling radiator silent block				X	
Engine Coolant		X*			
Engine silent block and its stop nuts		X			
Air intake SCEET pipes on airbox and on carburetors		X			
Cabin heating SCAT pipes					X
Air intake filter		X			
Nose landing gear bungee		X			
Nose landing gear plastic bushing				X	
Main landing gear red plastic (vulcolan)				X	
Tires				X*	
Brakes oil				X	
Brake lines				X	
Central bell crank of control system for pitch					X
Plastic bushing of torque tube of control system for rolling					X
Plastic fairleads of control system rudder cables					X
Pulley of control system rudder cables					
Flight control system bolts and stop nuts				X	
Parachute repack and rocket revision			X*		
Parachute bridles					12*

Table 16a

	<b>MAINTENANCE MANUAL SAVANNAH S</b>	Doc. No.: MM-SVNH-EN
		Revision: 07
		Rev. Date: 07/11/2022
		Proj. Ref.: SVNH S

System / part	Time limit [year]				
	1	5	6	10	20
Parachute rescue system lifetime					12*
Engine mechanical fuel pump		X*			
Carburetor sockets and diaphragm		X*			
Engine rubber hoses (fuel, oil, cooling, vents, compensation)		X*			
Propeller		X*			
Powerplant 12 month (if not performed 100 hrs)	X*				
Engine overhaul				X**	
ELT battery		X***			
ELT self test 3 month	X****				
ELT continuous airworthiness 1 year test	X				

**NOTE:**

\* For the parts highlighted with the star mark (\*), add the verification reported in the following Warning box.

\*\* Engine Rotax 912 ULS with S/N from 6775790 is increased at 15 years.

\*\*\* ELT battery expires after 5 year or before, as reported on the battery itself.

\*\*\*\* ELT self test every 3 month by pressing self test button.

*Table 16b (a-b): Time limits*

Tolerance of time limits is 5% or 6 month, which one is minor.

**WARNING**

Parts highlighted with the star mark (\*) are only given as a general indication. Each parts must be maintained and verified according to the time table or scheduled maintenance described in the approved Maintenance Manual of the manufacturer of each relative component

**WARNING**

Where the time limits *Table 16* prescribes a replacement of fastening (i.e. bolt and stop nut), perform additional controls of the surrounding and connected parts, monitoring the corrosion, cracks or eventual other problems

	<b>MAINTENANCE MANUAL SAVANNAH S</b>	Doc. No.: MM-SVNH-EN
		Revision: 07
		Rev. Date: 07/11/2022
		Proj. Ref.: SVNH S

#### 4. Maintenance Schedule

The maintenance schedule represents the intervals between each maintenance has to be executed on the aircraft and its systems. Reading the maintenance of the airframe and its systems, this interval is usually measured in terms of Flight Hours, which are the sum of differences of take-off and landing times for each flight. Instead, the maintenance of the powerplant is spaced in terms of Operating Hours, which is the sum of the entire period between the system is active (i.e. the engine is on, mainly). In order to not split the airframe and powerplant maintenance schedule, preventing confusion or problems of maintenance records, for the present manual is established to apply the maintenance schedule in respect of the most restrictive method, which is normally the Operating Hours of the engine. This time interval is indicated and measured by the digital Hourmeter instrument of the engine (or eventually the analogic one). Exception from this timing system is allowed only if a complete and detailed system of Flight Hours record (aircraft logbook and maintenance logbook) is used, in certified airport only (verifiable intervals of time).

Always record in the aircraft maintenance logbook the maintenance performed and any variations in respect of the scheduled list or unscheduled maintenance.

The maintenance action can be executed with a tolerance of +/-5 Operating Hours or +/-1 month (where applicable for this section) between two consecutive scheduled works. The next maintenance action must be planned by adding the interval from the Operating actual Hours of the last performed one: i.e., if the first one has been executed at 93 hours, the next one must be planned at  $93+50=143\pm 5$  [hrs]. The tolerance must not be used to plan each time the maintenance work increased of the tolerance itself; the schedule must be followed.

**WARNING**

**Exceeding the maintenance intervals of more than the Operating Hours plus tolerance established by the present aircraft Maintenance Manual or the equipment manufacturer Maintenance Manual implies a decline of airworthiness and can lead to a safety problems.**

**WARNING**

**For complete engine and other equipment checks and maintenance, always refer to the original approved Maintenance Manual and Service Bulletins issued by the manufacturer of each relative system.**

Maintenance work	Operating Hours												Year
	First 25	50	100	150	200	250	300	350	400	...	1000	2000	1
<b>50</b>	x	x	x	x	x	x	x	x	x	...	x	x	x
<b>100 h / 1 yrs</b>	x		x		x		x		x	...	x	x	x*
<b>200</b>					x				x	...	x	x	
<b>1000</b>										...	x	x	
<b>2000</b>										...		x	

**NOTE:** \* The maintenance called *100 flight hours / 1 year* is to perform alternatively every 100 operating hours or 1 year of time period starting from the last maintenance performed, whichever comes first.

*Table 17: Maintenance schedule*

	<b>MAINTENANCE MANUAL SAVANNAH S</b>	<b>Doc. No.:</b> MM-SVNH-EN
		<b>Revision:</b> 07
		<b>Rev. Date:</b> 07/11/2022
		<b>Proj. Ref.:</b> SVNH S

The maintenance action is seen as cumulative work: the 2000 hours (the highest) is composed by the 2000 hours tasks, with additionally the 1000 hrs checks and so on by the 200, 100 and 50 hours verifications. Therefore, the baseline is constituted by the 50 hrs, which is then expanded.

<b>Task / Action to do</b>	<b>Description</b>
Verify, Visual verification	All the following observation are compliant to the original installation and design: shape, integrity, correct position, correct fixing and supporting, no oxidation, no cracks, correct alignment, no oxidation, no abnormalities, marks of nut closure are aligned, best manufacturing and assembly practices
Check, manual verification	Check manually the parts, fixing, free play, if needed perform check of proper closure or operation / function of the system or parts, no abnormalities in respect of the original design or installation configuration
Replace	Change the part or assembly with a spare new one
Torque or Tension	Set or verify bolt/nut torque; set or verify cable tension
Marks	Verify green marks remaining after manufacturer production verifications. Verify bolt-nut red cross-check marks alignment. Make a new mark with not erasable pen or cross-check red torque seal
Lubricate	Clean and lubricate; if needed disassembly to clean and then lubricate
Measure	Measure a hole diameter or distance, clearance, free play

Table 18: Main maintenance tasks

If during a verification or check or other task, the result is not positive or is not compliant to the original installation, then is needed to apply a corrective action made to re-establish the original and safe installation of the system. To execute the recondition, rely on descriptions of the *Chapter 7* and refer to the approved manufacturer documentation of the airplane reported in *Chapter 1.24*.

When reported “if applicable” in a maintenance description, when the system or component is not installed, not part of the airplane configuration, the operation described can be avoided. In this occasion, the maintenance action cannot be applied, it is “not applicable”.

Each task inherent to any different equipment in respect of the airframe is taken from the manufacturer maintenance approved documentation and it is hereby shown for memorial purposes only. Always refer to the original continuous airworthiness documents of each equipment (i.e. engine, propeller, avionics and parachute rescue system) to execute the entire intervention on this system.

	<b>MAINTENANCE MANUAL SAVANNAH S</b>	<b>Doc. No.:</b> MM-SVNH-EN
		<b>Revision:</b> 07
		<b>Rev. Date:</b> 07/11/2022
		<b>Proj. Ref.:</b> SVNH S

#### 4.1. 50 Hours maintenance checklist

Structure / System	N°	Inspection item	Action / Description
Aircraft Safetying	00.01	Aircraft position	Safe hangar, aircraft free from obstacles and fixed on ground (chokes)
	00.02	Engine magneto switches	Verify OFF
	00.03	Master switch	Verify OFF
	00.04	Cowling, trap doors, inspection panels	Remove or open if required by the maintenance point
	00.05	Equipment	Verify parachute actuation handle with locking device installed. Verify other equipment are safe to operate with
Fuselage	01.01	Structure	Verify skin shape integrity, rivets all present and corrosion. Verify rivets one by one in the longitudinal stringers of rear wing attachments, in the front sides cabin frame connections, in the main landing gear attachments area and in the firewall to nose
	01.02	Wing attachments	Verify cabin frame welding no crack and attachments fork to wing plates integrity
	01.03	Strut and landing gear attachments	Verify struts attachments integrity, shape and welding no crack. Verify attachments connection to the fuselage integrity and bolts present
	01.04	Horizontal Tail attachments	Verify horizontal tail attachments angulars integrity, no cracks, rivets on side skin all present and blot with nut closed
	01.05	Vertical Tail attachments	Verify fin attachments to stabilizer integrity, no cracks, with rivets all present and bolt with nut closed. Verify rear fin attachments to fuselage bulkhead integrity, no side skin bent, no cracks and bolt with nut closed
	01.06	Ballistic rescue system	Verify parachute bridles near wing attachments are not damaged (if clearly visible). Verify parachute and rocket egress area integrity and with bridles protected by grommets. Verify rocket warning placard present
	01.07	Antennas	Verify antennas integrity and rigidly installed
	01.08	Firewall attachments to engine mount	Verify attachments of engine mount on firewall and surrounding areas

Table 19a



# MAINTENANCE MANUAL SAVANNAH S

<b>Doc. No.:</b>	MM-SVNH-EN
<b>Revision:</b>	07
<b>Rev. Date:</b>	07/11/2022
<b>Proj. Ref.:</b>	SVNH S

Structure / System	N°	Inspection item	Action / Description
Fuselage	01.09	Cabin frame	Verify all the cabin frame integrity, welding, corrosion, painted for protection. Verify rear aluminium side frame integrity (from spars attachments to rear wing attachments)
	01.10	Seats structure	Verify lower seats structure, front seats spar, back of seats and central tunnel for shape, integrity and connection to cabin
	01.11	Belt and Harnesses latches	Verify latches, regulators and connection device integrity and close regularly without sliding
	01.12	Belt and Harnesses attachments	Verify safety harnesses attachments bolts and nut are closed
	01.13	Baggage area	Verify structure shape and integrity especially in the sides. Verify hooks attachment and latches integrity
	01.14	Windshield and side windows	Verify front windshield and doors windows are clear from big scratches or obscured areas. Verify no big cracks. If small cracks adjacent to rivets are present, perform stop hole at the end of crack. Clean if necessary
	01.15	Doors	Verify rigidly hinged on cabin frame and closing correctly. Verify shape and integrity of door structure. Verify door handle properly working from internal and external, lubricate if required
	01.16	Instrument panel	Verify instrument panel and its support structure are rigid. Verify instruments, switches, circuit breakers, controls, are correctly installed and fixed
	01.17	Interiors	Inspect cabin interiors, verify are free from object, FOD, which can obstruct flight controls. If necessary, clean the cabin
Right Wing	02.01	Structure	Verify skin shape integrity and rivets all present, especially main spar and rear spar, verify one by one
	02.02	Flaperon support horns	Verify wing to flaperon supports plates correct shape, rivets all present and rigidity
	02.03	Attachments to fuselage	Verify front and rear spar attachment plates integrity, bolt and nut closed (mark alignment)

Table 19b





# MAINTENANCE MANUAL SAVANNAH S

<b>Doc. No.:</b>	MM-SVNH-EN
<b>Revision:</b>	07
<b>Rev. Date:</b>	07/11/2022
<b>Proj. Ref.:</b>	SVNH S

Structure / System	N°	Inspection item	Action / Description
Right Wing	02.04	Attachments to struts	Verify front and rear spar attachment plates integrity, bolt and nut closed (mark alignment)
	02.05	Struts	Verify front and rear strut shape and straight. Verify upper and lower fork integrity, bolt and nut closed (mark alignment)
	02.06	Jury strut	Verify jury strut integrity and shape, rigid connection to spar
	02.07	Vortex	All present
	02.08	Tip	Verify tip corners integrity and light support is fixed rigidly. Check light function (if installed)
Right Flaperon	03.01	Structure	Verify skin shape integrity and rivets all present. Verify connection plates and bolt with stop nut closed between the inboard and outboard flaperon
	03.02	Hinges	Verify hinge points with castle nut and cotter pin properly fixed and free play within tolerances. Clean and lubricate if necessary
	03.03	Control system horn	Verify control horn bolts and stop nuts closed. Verify rotation is free with clearance with the fuselage structure
	03.04	Surface travel	Verify flaperon free in its entire travel. Check surface deflection angles if any part of the control system has been modified or dismantled (included flap lever or actuator); check also surface deflation angles in case of flap function operation, with coherency of the flap indicator for the entire travel. Verify flaperon angular free play within tolerance (with control fixed)
	03.05	Tip cover	Verify rigidly supported

Table 19c



# MAINTENANCE MANUAL SAVANNAH S

**Doc. No.:** MM-SVNH-EN

**Revision:** 07

**Rev. Date:** 07/11/2022

**Proj. Ref.:** SVNH S

Structure / System	N°	Inspection item	Action / Description
Left Wing	04.01	Structure	Verify skin shape integrity and rivets all present, especially main spar and rear spar verify one by one
	04.02	Flaperon support horns	Verify wing to flaperon supports plates correct shape, rivets all present and rigidity
	04.03	Attachments to fuselage	Verify front and rear spar attachment plates integrity, bolt and nut closed (mark alignment)
	04.04	Attachments to struts	Verify front and rear spar attachment plates integrity, bolt and nut closed (mark alignment)
	04.05	Struts	Verify front and rear strut shape and straight. Verify upper and lower fork integrity, bolt and nut closed (mark alignment)
	04.06	Jury strut	Verify jury strut integrity and shape, rigid connection to spar
	04.07	Pitot tube	Verify pitot is rigidly installed, aligned to the wing lower skin and straight. Verify hole is free and no moisture in the pipes (looking under the instrument panel the ASI pipes)
	04.08	Vortex	All present
	04.09	Landing light	Verify structure is rigid. Check light function (if installed)
	04.10	Tip	Verify tip corners integrity and light support is fixed rigidly. Check light function (if installed)
Left Flaperon	05.01	Structure	Verify skin shape integrity and rivets all present. Verify connection plates and bolt with stop nut closed between the inboard and outboard flaperon
	05.02	Hinges	Verify hinge points with castle nut and cotter pin properly fixed and free play within tolerances. Clean and lubricate if necessary
	05.03	Control system horn	Verify control horn bolts and stop nuts closed. Verify rotation is free with clearance with the fuselage structure
	05.04	Surface travel	Concomitant to the Right Flaperon (see above)
	05.05	Tip cover	Verify rigidly supported

Table 19d



# MAINTENANCE MANUAL SAVANNAH S

<b>Doc. No.:</b>	MM-SVNH-EN
<b>Revision:</b>	07
<b>Rev. Date:</b>	07/11/2022
<b>Proj. Ref.:</b>	SVNH S

Structure / System	N°	Inspection item	Action / Description
Stabilizer	06.01	Structure	Verify skin shape integrity and rivets all present
	06.02	Attachments	Verify attachment plates and stop nut closed
	06.03	Tip cover	Verify rigidly supported
	06.04	Elevator support horns	Verify no crack, all rivets installed and rigidity
Elevator	07.01	Structure	Verify skin shape integrity and rivets all present
	07.02	Hinges	Verify hinge points with castle nut and cotter pin properly fixed and free play within tolerances. Clean and lubricate if necessary
	07.03	Elevator control system horn	Verify control system horn plates and rivets all present
	07.04	Surface travel	Verify elevator free in its entire travel. Check surface deflection angles if cable tension has been modified. Verify elevator angular free play within tolerance (with control fixed)
	07.05	Tip cover	Verify rigidly supported
Trim Tab	08.01	Structure	Verify skin and riveted lines
	08.02	Hinge	Verify central horn (same of elevator hinge point) free play within tolerance and castle nut with cotter pin properly closed. Verify trim tab hinge line free play within tolerance. Clean and lubricate if necessary
	08.03	Actuation	Check actuator works coherently with cabin control and trim indication. Verify trim travel is free for all elevator deflections, no push-pull rods and trim surface interference. Verify push-pull rods and uniball are closed. Verify trim tab angular free play within tolerance
Vertical Tail (Fin)	09.01	Structure	Verify skin shape integrity and rivets all present
	09.02	Attachments	Verify attachment plates and stop nut closed
	09.03	Tip cover	Verify rigidly supported

Table 19e



## MAINTENANCE MANUAL SAVANNAH S

<b>Doc. No.:</b>	MM-SVNH-EN
<b>Revision:</b>	07
<b>Rev. Date:</b>	07/11/2022
<b>Proj. Ref.:</b>	SVNH S

Structure / System	N°	Inspection item	Action / Description
Rudder	10.01	Structure	Verify skin shape integrity and rivets all present
	10.02	Hinges	Verify hinge points with castle nut and cotter pin properly fixed and free play within tolerances. Clean and lubricate if necessary
	10.03	Flight control system horn	Verify control system horn plates and rivets all present
	10.04	Surface travel	Verify rudder free in its entire travel (pull-up the nose and consider the steering friction not excessive). Check surface deflection angles if cable tension has been modified. Verify rudder angular free play within tolerance (with control fixed)
	10.05	Tip cover	Verify rigidly supported
Flight Control System	11.01	Primary control excursion	Verify control stick free around the entire travel and corners, including roll. Verify control stick cuff (if installed) integrity and not limiting the stick travel
	11.02	Stick	Verify stick grip integrity and not rotating
	11.03	Joint and hinges (rotating points)	Verify all the joint of control stick with castle nut and cotter pin properly installed or self-locking nut closed. Verify push-pull rods and uniball properly closed and free to rotate laterally. Verify all free play are in tolerance. Lubricate rotating points if necessary
	11.04	Elevator cables	Check cable tension is 18-24 [lbs] (9-12 [kg]) with dedicated instrument. Verify cable integrity and terminal fitting (nicopress, cable redance). Verify closure of nonio tender
	11.05	Directional control system	Verify rudder pedals free around the entire travel, plastic hinge on floor not forcing and properly closed bolt with self-locking nut. Verify brake pedals and pumps not limiting the rudder travel. Verify pedal bars and brake pedals integrity and welding, no cracks. Verify steering push-pull rods connected with cotter pin to the pedals. Clean and lubricate rotating points if necessary

Table 19f



# MAINTENANCE MANUAL SAVANNAH S

<b>Doc. No.:</b>	MM-SVNH-EN
<b>Revision:</b>	07
<b>Rev. Date:</b>	07/11/2022
<b>Proj. Ref.:</b>	SVNH S

Structure / System	N°	Inspection item	Action / Description
Flight Control System	11.06	Rudder cables	Check cable tension is 11-15 [lbs] (5-7 [kg]) with dedicated instrument. Verify cable integrity and terminal fitting (nicopress, cable redance). Verify nonio tender closed. Verify pulleys round, safety pin installed and plastic fairleads hole not ovalized. Clean and lubricate passages and joint if necessary
	11.07	Brake pedals	Verify brake pumps are correctly supported and connected to the pedals. Verify no leakage from pipes and fittings; on pumps cup small sign of oil is acceptable
Main landing gear	12.01	Support structure	Verify integrity of landing gear attachments. Verify vertical bolt and nut correctly closing the spring with red rubber (vulcolan) and lower plate in correct position and integrity
	12.02	Spring	Verify landing gear spring no damages, no unsymmetrical shape (within tolerances)
	12.03	Axle	Verify ring nut with teeth washer closed, both on the spring and on the wheel side
	12.04	Brakes	Verify brakes caliper free play along wheel axis and blots closed. Verify no oil leakage and brake pipes integrity. Verify brake pads consumption (change if required or friction material is less than 3 [mm])
	12.05	Wheel	Verify visually that wheel rim is round and disc fixed
	12.06	Tyre	Verify tyre consumption (replace if necessary). Verify pressure from 1.5 to 2.5 [bar], as required by the wheel type
	12.07	Fairing	Verify wheel fairings rigidly supported and not damaged

*Table 19g*



# MAINTENANCE MANUAL SAVANNAH S

<b>Doc. No.:</b>	MM-SVNH-EN
<b>Revision:</b>	07
<b>Rev. Date:</b>	07/11/2022
<b>Proj. Ref.:</b>	SVNH S

Structure / System	N°	Inspection item	Action / Description
Main landing gear tail dragger (if configured with)	12b.01	Brace rods (add to the previous list)	Verify main landing gear spring brace rods integrity, no cracks on welding at the ends, uniball closed
Nose landing gear	13.01	Support structure	Verify integrity of landing gear leg, lower structural box, leg spar and upper landing gear support on the firewall
	13.02	Fork	Verify fork is straight
	13.03	Axle	Verify ring nut with teeth washer closed and bolts on axle closed with safety wires
	13.04	Free play	Check the free play of the landing gear leg lower sliding plates, not major than 2 [mm] (if necessary replace)
	13.05	Lubrication	Lubricate with white grease the nose landing gear sliding and rotating points
	13.06	Shock absorber	Verify bungee enough strong against compression, it must stay totally extended (at empty weight) after return from a 5 [cm] manual compression
	13.07	End of run	Verify integrity of end of run absorber (red vulcolan ring)
	13.08	Steering rods	Verify uniball of push-pull rods of steering are closed, both for nose leg and cabin sides. Verify no rubbing in firewall holes for the entire travel
	13.09	Wheel	Verify wheel rim perfectly round
	13.10	Tyre	Verify tyre consumption (replace if necessary). Verify pressure from 1.5 to 2.5 [bar], as required by the wheel type
	13.11	Fairing	Verify nose wheel fairing rigidly supported and not damaged

*Table 19h*

	<b>MAINTENANCE MANUAL SAVANNAH S</b>	<b>Doc. No.:</b> MM-SVNH-EN
		<b>Revision:</b> 07
		<b>Rev. Date:</b> 07/11/2022
		<b>Proj. Ref.:</b> SVNH S

Structure / System	N°	Inspection item	Action / Description
Tail landing gear (if configured with)	13b.01	Spring	Verify integrity of spring, no crack, no scratches, lower structural plate of attachments with its bolt, properly closed. Verify tail fuselage reinforcement and bulkheads rivets all present. Verify spring rubber pad (red vulcolan) in position
	13b.02	Tail wheel	Verify tail wheel attachment bolt closed and rotating castle nut fixed with cotter pin. Verify tail wheel steering horn free to rotate with rudder and wheel. Verify tail wheel disengage from directional control system for excessive angle defection
	13b.03	Cables	Verify rudder to steering horn and steering horn to tail wheel cables are in tension and springs present
	13b.04	Alignment	Verify rudder aligned with tail wheel
	13b.05	Lubrication	Lubricate with white grease all the rotating points
Engine cowling	14.01	Integrity	Remove the upper and lower cowling and verify all the parts of the cowling, internal and external, upper part
	14.02	Attachments	Verify cowling to fuselage attachments and connections between the lower and upper part. DZUS bolt and its spring close in same
	14.03	Match	Verify the upper and lower part match correctly, DZUS bolts with plastic washer and their spring are closing firmly. At the end of maintenance, re-install the engine cowling. Verify intake Naca is almost aligned to the airbox intake cold air opening and not obstructed
Propeller	15.01	Prop. Maintenance Manual	Apply manufacturer approved documentation for Maintenance and Service Bulletin
	15.02	Blades	Verify blades rigidity around rotation and traction axis at the blade tip, all coherent and rigid. Verify blades shape and leading edge integrity, dents and cracks absent

Table 19i



# MAINTENANCE MANUAL SAVANNAH S

<b>Doc. No.:</b>	MM-SVNH-EN
<b>Revision:</b>	07
<b>Rev. Date:</b>	07/11/2022
<b>Proj. Ref.:</b>	SVNH S

Structure / System	N°	Inspection item	Action / Description
Propeller	15.03	Spinner	Verify integrity and rigidity. Verify all bolt presence. Verify positive clearance with the engine cowling (no scratches between the parts)
Engine	16.01	Engine Maintenance Manual	Apply manufacturer approved documentation for Maintenance and Service Bulletin. Verify also applicability of 100 hrs engine maintenance if used more than 30% of leaded fuel
	16.02	Mount	Verify welding, general shape/integrity, no corrosion, silent blocks, stop nut (or castle nut) present on inner ring, attachments to the structure and engine
	16.03	Case and accessories	Verify general integrity of all the parts, included crankcase, gearbox, cylinder, heads, probes, magneto units and their suspension, spark plug harnesses, wirings, pipes, accessories
	16.04	Cleaning	If necessary, clean the engine parts
Powerplant controls	17.01	Throttle lever	Verify throttle knob, push-pull bar and passage in firewall. Check throttle run and friction (only left side present)
	17.02	Throttle torque tube and supports	Verify tube, its plastic bushing and lateral supports, no crack in horns welding
	17.03	Throttle cables	Verify carburettor cables integrity, stop screw on cable. Verify bowden to carburettor integrity and routing with large curve and properly supported. Verify bowden ends connected to supports and safety wire locking aligned
	17.04	Throttle travel, stops	Check travel and end of run stop in idle touching simultaneously to carburettor stop. Verify full throttle stop corresponding to more than maximum in carburettor (cable clearance)
	17.05	Throttle lubrication	If needed, clean and lubricate all the rotating points and carburettor wires
	17.06	Carburettor heating cable	Verify carburettor heating knob and bowden fitting in firewall. Verify cable stop nut on airbox valve lever

Table 19j





# MAINTENANCE MANUAL SAVANNAH S

<b>Doc. No.:</b>	MM-SVNH-EN
<b>Revision:</b>	07
<b>Rev. Date:</b>	07/11/2022
<b>Proj. Ref.:</b>	SVNH S

Structure / System	N°	Inspection item	Action / Description
Powerplant controls	17.07	Carburettor heating function	Check carburettor heating run and function properly on the airbox valve: pull to open and remains open if knob left free (spring on airbox valve lever)
	17.08	Carburettor heating pipe	Verify SCAT pipe routing and fixing from the exhaust plate to the intake hot air of the airbox
	17.09	Carburettor heating system lubrication	If needed, clean and lubricate all the rotating points, knob axle and wire
	17.10	Choke system	Verify choke knob and bowden fitting in firewall. Verify cable division device, correct support and routing or the bowden. Bowden terminals on carburettors with safety wire
	17.11	Choke function	Check choke function properly on the carburettor dedicated arm: pull to activate and it returns automatically deactivated
	17.12	Choke system lubrication	If needed, clean and lubricate all the rotating points, knob axle and wire
	17.13	Propeller control electric (if provided)	Check switch function on propeller blades pitch (RPM increase, switch up, pitch decrease)
	Fuel system	18.01	Leakages
18.02		Pipes	Verify integrity, wearing, correct installation, protection and supporting
18.03		Hoses	Verify hoses installation in all pipes connection and fitting, metal clamp closed firmly
18.04		Vents	Fuel vent pipes free, check with small pressure with the cup open. Verify vent correctly installed on cup and wing lower skin
18.05		Wing tanks	Verify tank cup seals properly on its socket. Verify no leakage from cup socket and plastic cover (externally)
18.06		Collector tank	Verify support, reserve probe connections, fittings on tank are rigid
18.07		Fuel shut off valve	Verify shut off valve installation, rigidly supported, remains open with safety wire and coherent placard indication
18.08		Fuel filter	Verify fuel filter integrity and colour clean, without deposits

Table 19I



# MAINTENANCE MANUAL SAVANNAH S

<b>Doc. No.:</b>	MM-SVNH-EN
<b>Revision:</b>	07
<b>Rev. Date:</b>	07/11/2022
<b>Proj. Ref.:</b>	SVNH S

Structure / System	N°	Inspection item	Action / Description
Fuel system	18.09	Instrument and reserve warning	Verify fuel pressure instrument well supported on the panel, pressure pipe and filter properly connected behind Check function with auxiliary fuel pump active (or engine run-up test verification)
	18.10	Spider junction	Verify rigidly supported and fittings closed. Verify only two restrictor installed on the return line and pressure instrument line (aluminium fitting with marks on hexagonal corner)
	18.11	Mechanical fuel pump	Verify fittings and vent pipe
	18.12	Carburettors	Verify carburettor connections and float chamber spring closed. Check float chamber and clean as required
Water system	19.01	Coolant level	Verify coolant level in the expansion tank, over the transparent bubble dot. Verify level in the overflow bottle, approximately half. Verify coolant cleanness and if required flush or replace the coolant
	19.02	Leakages	Verify no leakages, following all the system parts (hoses, fitting, pipes, radiator)
	19.03	Coolant tanks	Verify expansion tank integrity, supported and protected from the engine. Verify overflow bottle integrity, supported and constrained on the firewall
	19.04	Pipes	Verify integrity, wearing, correct installation and supporting
	19.05	Hoses	Verify hoses installation in all pipes connection and fitting, metal clamp closed firmly
	19.06	Radiator	Verify radiator, supports and silent block integrity and wearing
	19.07	Instrument	Verify coolant temperature probes connected to the electric wires (cylinder heads). Verify water temperature instruments well supported on the panel and wires connected behind (or engine run-up test verification)
	19.08	Cleaning	If needed, clean to inspect and verify

Table 19m



## MAINTENANCE MANUAL SAVANNAH S

<b>Doc. No.:</b>	MM-SVNH-EN
<b>Revision:</b>	07
<b>Rev. Date:</b>	07/11/2022
<b>Proj. Ref.:</b>	SVNH S

Structure / System	N°	Inspection item	Action / Description
Oil system	20.01	Oil level	Verify oil level in the oil tank by means of dipstick indication. Before the level verification, check both magneto switches are OFF, make rotating the propeller by hand (right turn from pilot view) until hearing gurgle from the oil tank. If necessary, add oil
	20.02	Leakages	Verify no leakages, following all the system parts (hoses, fitting, pipes, radiator)
	20.03	Oil tank	Verify tank integrity, supported and protected from engine mount. Verify all fittings connected, vent pipe, draining bolt and its safety wire
	20.04	Pipes	Verify integrity, wearing, correct installation and supporting
	20.05	Hoses	Verify hoses installation in all pipes connection and fitting, metal clamp closed firmly
	20.06	Radiator	Verify radiator, supports and silent block integrity and wearing
	20.07	Oil filter	Verify closed firmly or red marking aligned
	20.08	Instrument	Verify oil pressure and temperature probes connected to the electric wires (oil pump and filter area). Verify oil pressure and temperature instruments well supported on the panel and wires connected behind (or engine run-up test verification)
	20.09	Cleaning	If needed, clean to inspect and verify
Intake system	21.01	Air intake port	Verify intake port free
	21.02	Airbox integrity and supports	Verify airbox integrity and supports on engine mount
	21.03	Air Filter	Verify integrity, clean or replace if necessary
	21.04	Airbox connection to Carburettors	Verify airbox connected to carburettors, SCEET pipes integrity and clamped firmly
	21.05	Carburettor fixing	Verify carburettors socket are strongly connected to the engine

Table 19n

	<b>MAINTENANCE MANUAL SAVANNAH S</b>	<b>Doc. No.:</b> MM-SVNH-EN
		<b>Revision:</b> 07
		<b>Rev. Date:</b> 07/11/2022
		<b>Proj. Ref.:</b> SVNH S

Structure / System	N°	Inspection item	Action / Description
Exhaust system	22.01	Collectors	Verify rigidity, fixing plate and nut, welds, springs and hooks of connection to muffler, clearance with any other part. Verify no sign of gases
	22.02	Muffler	Verify rigidity, clearance with any other part, welds, heating chamber. Verify integrity of cylinder body, sides collectors connection, cabin heating chamber and terminal rigidity
Cabin heating	23.01	Hot air pipes	Verify fixing and correct clamping of the SCAT pipes of Airbox, muffler to valve and cabin
	23.02	Cabin heating valve	Check cabin heating knob and bowden supported and operating correctly the valve (pull to open). If needed, clean and lubricate all the rotating points and wire
Electrical system	24.01	Battery	Verify battery support and absence of corrosive fluids or structure corrosion. Verify wires terminals on poles are fixed
	24.02	Circuit breakers	Verify wiring terminals all connected to the breaker below the instrument panel
	24.03	Wirings	Verify wirings all suspended behind the panel, no connectors free or uncovered, no wires worn, no oxidation. Verify mass connected to the structure
	24.04	Fittings	Verify firewall fittings rigid and sealed
	24.05	Battery general fuse	Verify battery fuse integrity, case and cables without sign of heating or damages and properly suspended
	24.06	Rectifier unit	Verify fixed to the firewall, connector and wirings without any sign of heating or damages
	24.07	Starter relay	Verify starter relay rigidly supported. Verify wiring on poles fixed and protected
	24.08	Engine electric starter	Verify connectors fixed, wirings insulated and supported to the engine mount without any damages
	24.09	Engine mass	Verify engine mass connected to the aircraft structure mass and all parts are properly fixed

Table 19o



# MAINTENANCE MANUAL SAVANNAH S

<b>Doc. No.:</b>	MM-SVNH-EN
<b>Revision:</b>	07
<b>Rev. Date:</b>	07/11/2022
<b>Proj. Ref.:</b>	SVNH S

Structure / System	N°	Inspection item	Action / Description
Markings and placards	25.01	Markings and placards	Verify all instrument marking present (red limits for engine indications and arcs for airspeed). Verify switches and secondary controls placard present Verify
Ground run up check (apply section only if required)	26.01	Engine warm up	Perform
	26.02	Engine instruments and Control switches	Check normal parameters and function
	26.03	COM system	Check function
	26.04	ELT system	Check function
	26.05	Engine RPM minimum	Check and eventually adjust
	26.06	Engine/propeller maximum rotating speed	Check and eventually adjust the propeller blades pitch or governor regulations
	26.07	Propeller control (if provided)	Check propeller speed RPM decrease when propeller knob is pulled (if provided hydraulic control, governor)
	26.08	Carburettor balancing	If needed, check and align
Flight check	27.01	Primary flight controls	Check on ground smooth and free around the entire travel. Check in flight normal flying qualities (controls response)
	27.02	Secondary controls	Check function
	27.03	Primary instruments	Check function and normal parameters
	27.04	Engine instruments	Check function and normal parameters
	27.05	Switches	Check function
	27.06	COM system	Check function (if required)
	27.07	TRX system	Check function (if required)
Avionics	28.01	Manufacturer Manual	Operate maintenance as required
Other equipment	29.01	Equipment Manufacturer Manual	Operate maintenance and Service Bulletin as required (i.e.: ballistic parachute rescue system maintenance manual)
Maintenance close out	30.01	A/C SB	Check last updated and approved documentation at the continuous airworthiness page of the manufacturer, by logging in at <a href="http://www.icpaviation.it">www.icpaviation.it</a> / MY I.C.P. Verify aircraft Service Bulletin and execute if applicable
	30.02	Foreign Object Debris	Verify the absence of FOD in any part of the aircraft

Table 19p

	<b>MAINTENANCE MANUAL SAVANNAH S</b>	<b>Doc. No.:</b> MM-SVNH-EN
		<b>Revision:</b> 07
		<b>Rev. Date:</b> 07/11/2022
		<b>Proj. Ref.:</b> SVNH S

<b>Structure / System</b>	<b>N°</b>	<b>Inspection item</b>	<b>Action / Description</b>
Maintenance close out	30.03	Cowling, trap doors, inspection panels	Verify all cowling, fairing and inspection panels are installed and closed
	30.04	Fuel shut-off valve	Verify the fuel shut off valve is open and with safety wire
	30.05	Maintenance record	Fill-in the aircraft maintenance logbook and equipment logbook with correspondent maintenance and effective flight hours

*Table 19q (a-q): 50 [hrs] scheduled maintenance*

	<b>MAINTENANCE MANUAL SAVANNAH S</b>	<b>Doc. No.:</b> MM-SVNH-EN
		<b>Revision:</b> 07
		<b>Rev. Date:</b> 07/11/2022
		<b>Proj. Ref.:</b> SVNH S

## 4.2. 100 Hours / 1 Year maintenance checklist

The 100 hours complete maintenance requires that a 50 hours inspection has been carried out plus the tasks below stated.

Structure / System	N°	Inspection item	Action / Description
Elevator	07.06	Stops and skin	Verify lower stop with pads and not damaging the surface skin. Verify upper stop (fin skin) properly protected and no damages
Rudder	10.06	Stops and skin	Verify rudder stop (lower hinges) and skin not damaged
Flight Control System	11.08	Elevator control system	Verify the bell crank supporting the cables: plastic hinge and bushing free play not excessive, lubricate if necessary. Verify bell crank stops and supporting structure with no crack and all rivets. Verify bell crank castle nut and cotter pin. Verify push-pull rod not scratching laterally
	11.09	Flaperon control system	Verify torque tube support structure (fuselage bulkhead). Verify torque tube hinges free play not excessive and bolt with stop nut closing properly the roll bell crank. Verify hinges free play and bolt with stop nut closed of the bell cranks supported by the flaperon triangular mixer. Verify flaperon mixer support structure and hinge integrity and without free excessive free play. All push-pull rod uniball without excessive free play and properly closed. Lubricate all the parts if necessary
	11.10	Rudder pedals alignment	Verify the pedals are aligned when rudder is centred. Verify nose wheel is straight when rudder pedals are aligned
	11.11	Brake pedals alignment	Verify brake pedals aligned and breaking action is simultaneous
	11.12	Brakes lines	Verify no bubbles major than 20 [mm] on the pipes and oil quality (colour "clean"), if required purge the brakes oil system

Table 20a



## MAINTENANCE MANUAL SAVANNAH S

<b>Doc. No.:</b>	MM-SVNH-EN
<b>Revision:</b>	07
<b>Rev. Date:</b>	07/11/2022
<b>Proj. Ref.:</b>	SVNH S

Structure / System	N°	Inspection item	Action / Description
Engine	16.01	Engine Maintenance Manual	Apply manufacturer approved documentation for Maintenance
	16.05	Magnetic plug	Check magnetic plug
	16.06	Idle	Check engine idles speed
	16.07	Carburettors	Check carburettors mechanic and pneumatic synchronization
	16.08	Floater	Check floater weight only if not performed a 200 hrs maintenance task within the last 1 year
	16.09	Spark plugs	Remove spark plugs and check heat range designation, clean, check electrode gap. Replace if required
	16.10	Friction torque	Check friction torque in free rotation on gearboxes with overload clutch. Record friction torque in [Nm]
	16.11	Engine turning	Inspect and record the torque only in case of suspected hard movement
Oil system	20.10	Oil	Drain oil from oil tank (reduced at 50 hrs if used more than 30% of leaded fuel)
	20.11	Oil filter	Remove oil filter, inspect the filter by cutting it, and then install a new one (reduced at 50 hrs if used more than 30% of leaded fuel). Record findings in the filter: mat, cover, sealing lip, by pass spring, spring positioning
	20.12	Oil refill	Refill oil tank with approx. 3 [lt]
	20.13	Oil level	Check oil level
Intake system	21.06	Air filter	Clean the air filter and if necessary replace
Ground run up check	26.09	Engine run up test	Perform run test and check magnetos unit drops, carburettor heating system, operating temperatures and pressures in all instrument indications
Maintenance close out	30.06	General engine verification	Verify no leakages in powerplant area and re-tight the oil filter

*Table 20b (a-b): 100 [hrs] scheduled maintenance*



	<b>MAINTENANCE MANUAL SAVANNAH S</b>	<b>Doc. No.:</b> MM-SVNH-EN
		<b>Revision:</b> 07
		<b>Rev. Date:</b> 07/11/2022
		<b>Proj. Ref.:</b> SVNH S

### 4.3. 200 Hours maintenance checklist

The 200 hours complete maintenance requires that a 100 hours inspection has been carried out plus the tasks below stated.

Structure / System	N°	Inspection item	Action / Description
Fuselage	01.18	Internal corrosion	Verify absence of any sign of corrosion mainly in the Collector tank and fuel lines areas, control system areas, wiring passage areas, interface between structural parts
Flight control system	11.13	Control surfaces excursion	Check control surface range is within limits and tolerances
Main landing gear	12.08	Main spring constrains	Check the closure of the main spring bolts and stop-nuts
Propeller	15.04	Bolts	Check propeller hub and blades hub bolts torque. Make a new safety wiring on each bolt. Reinstall the spinner and check closure of its screws
	15.05	Balancing	Verify presence of balance weights in marked position. If absent (lost) or reported abnormal vibrations, perform propeller balancing and blades pitch verification (maximum Prop. RPM)
Engine	16.01	Engine Maintenance Manual	Apply manufacturer approved documentation for Maintenance
	16.12	Compressions	Check the compression by the differential pressure of cylinders and record the values
	16.13	Float chambers	Check ventilation of float chambers are free
	16.14	Floaters	Check weight of each floater
	16.15	Carburettors	Removal/assembly of the two carburettors for inspection
	16.16	Sockets	Check carburettors socket, absence of damage, cracks, abnormalities and wearing condition
	16.17	Spark plug connectors	Check spark plug connectors resistance to removal by spark plug (min. 30[N] of pull-off force)
	16.18	Spark plugs	Replace all spark plugs every 400 flight hours. Replace all at 200 hours only if used more than 30% of leaded fuel

Table 21a



# MAINTENANCE MANUAL SAVANNAH S

<b>Doc. No.:</b>	MM-SVNH-EN
<b>Revision:</b>	07
<b>Rev. Date:</b>	07/11/2022
<b>Proj. Ref.:</b>	SVNH S

Structure / System	N°	Inspection item	Action / Description
Fuel system	18.13	Auxiliary fuel pump	Verify installation rigid and check function (or engine run-up test verification)
	18.14	Mechanical pump vent	Check mechanical fuel pump vent is free
	18.15	Fuel filters	Replace fuel filters (excluding the fuel pressure instrument fuel filter)
Water system	19.09	Coolant tanks	Check overflow bottle cup is tighten, pipe is sealed in the passage of cup and venting hole in the cup is free. Check pipe between expansion tank and overflow bottle is free and arrives in the bottom of overflow tank. Check overflow tank bottom is free from deposits (coolant is clean); if different, change the coolant in the overflow bottle (or in flush the entire system) and refill at half level
	19.10	Radiator	Check radiator silent blocks nuts are closed
Oil system	20.14	Oil radiator	Check radiator silent blocks nuts are properly closed on radiator supports
	20.15	Oil tank	Check oil tank and clean if contaminated (reduced at 100 hrs if used more than 30% of leaded fuel)
Intake system	21.07	Airbox	Clean the airbox internally and lubricate the hinge of the air valves
	21.08	Airbox drains	Check airbox drain pipes are free
	21.09	Airbox connection to Carburettors	Verify airbox to carburettors connection SCEET pipes integrity, humidity sign and internal cleanness. Replace if required. Then re-install and verify clamped firmly.
	21.10	Carburettor heating pipe	Verify SCAT pipe integrity, routing and fixing from the exhaust plate to the intake hot air of the airbox
Flight check	27.08	Trim tab	Verify correct trim airspeed range minimum and maximum, change setting if necessary
	27.09	Flaperon	Verify the Flap indicator coherent for all settings and airspeed white range
	27.10	Rudder ground adjustable tab	Verify setting for cruise level flight and readjust the flattener tab to obtain directionally aligned flight if required

*Table 21b (a-b): 200 [hrs] scheduled maintenance*

	<b>MAINTENANCE MANUAL SAVANNAH S</b>	<b>Doc. No.:</b> MM-SVNH-EN
		<b>Revision:</b> 07
		<b>Rev. Date:</b> 07/11/2022
		<b>Proj. Ref.:</b> SVNH S

#### 4.4. 1000 hours maintenance checklist

The 1000 hours complete maintenance requires that a 200 hours inspection has been carried out plus the tasks below stated.

Structure / System	N°	Inspection item	Action / Description
Fuselage	01.19	Wing attachments	Check all the attachments internal diameter, within 0.3 [mm] tolerance in respect of nominal bolt diameter
	01.20	Stabilizer attachments	Check all the attachments internal diameter, within 0.2 [mm] tolerance in respect of nominal bolt diameter
	01.21	Fin attachments	Check all the rear fin attachments in the fuselage side, internal diameter within 0.2 [mm] tolerance in respect of nominal bolt diameter
	01.22	Attachment bolts and stop nuts	Replace all the connection bolts/nuts and check proper closure torque. Add mark
	01.23	Rudder hinge horn holes	Check all the hinge horn holes internal diameter, within 0.2 [mm] tolerance in respect of nominal bushing diameter
Right wing	02.09	Attachments	Check all the attachments internal diameter, within 0.3 [mm] tolerance in respect of nominal bolt diameter
	02.10	Struts fork	Check all the attachments internal diameter, within 0.3 [mm] tolerance in respect of nominal bolt diameter
	02.11	Attachment bolts and stop nuts	Replace all the connection bolts/nuts and check proper closure torque
	02.12	Flaperon horns	Check all the hinge line holes within 0.2 [mm] tolerance in respect of FCS bushing external diameter
Right Flaperon	03.06	Hinges	Replace all bolts, castle nuts with cotter pins and bushings of control surface
	03.07	Hinge horn holes	Check all the hinge horn holes internal diameter, within 0.2 [mm] tolerance in respect of nominal bushing diameter
Left wing	04.11	Attachments	Check all the attachments internal diameter, within 0.3 [mm] tolerance in respect of nominal bolt diameter
	04.12	Struts fork	Check all the attachments internal diameter, within 0.3 [mm] tolerance in respect of nominal bolt diameter

Table 22a



# MAINTENANCE MANUAL SAVANNAH S

<b>Doc. No.:</b>	MM-SVNH-EN
<b>Revision:</b>	07
<b>Rev. Date:</b>	07/11/2022
<b>Proj. Ref.:</b>	SVNH S

Structure / System	N°	Inspection item	Action / Description
Left wing	04.13	Attachment bolts and stop nuts	Replace all the connection bolts/nuts and check proper closure torque. Add mark
	04.14	Flaperon horns	Check all the hinge line holes within 0.2 [mm] tolerance in respect of FCS bushing external diameter
	04.15	Pitot	Disconnect the dynamic pipe of the Airspeed Indicator instrument. Check pitot pipe line maintain pressure of 0.3 [bar] for about one minute. If not, replace the line and/or fittings
	04.16	Static system	Disconnect all the pneumatic instruments from the static pipe line. Check static system maintain pressure of 0.3 [bar] for about one minute. If not, replace the line and/or fittings
Left Flaperon	05.06	Hinges	Replace all bolts, castle nuts with cotter pins and bushings of control surface
	05.07	Hinge horn holes	Check all the hinge horn holes internal diameter, within 0.2 [mm] tolerance in respect of nominal bushing diameter
Stabilizer	06.05	Attachments	Check all the attachments internal diameter, within 0.2 [mm] tolerance in respect of nominal bolt diameter
	06.06	Attachment bolts and stop nuts	Replace all the connection bolts/nuts and check proper closure torque. Add mark
	06.07	Fin attachments	Check the fin attachment holes within 0.2 [mm] tolerance in respect of nominal bolt diameter
	06.08	Elevator hinge horn holes	Check all the hinge horn holes internal diameter, within 0.2 [mm] tolerance in respect of nominal bushing diameter
Elevator	07.07	Hinges	Replace all bolts, castle nuts with cotter pins and bushings of control surface
	07.08	Hinge horn holes	Check elevator central horn with particular attention to cracks in the corners, missing/loosing rivets and rigidity of assembly in lateral direction. Check elevator lateral horns with particular attention to cracks and riveted areas. Check all hinge holes within tolerance of 0.2 [mm] in respect of the nominal bolt diameter

Table 22b



# MAINTENANCE MANUAL SAVANNAH S

<b>Doc. No.:</b>	MM-SVNH-EN
<b>Revision:</b>	07
<b>Rev. Date:</b>	07/11/2022
<b>Proj. Ref.:</b>	SVNH S

Structure / System	N°	Inspection item	Action / Description
Vertical tail (Fin)	09.04	Attachments	Check all the rear attachments internal diameter, within 0.2 [mm] tolerance in respect of nominal bolt diameter. Check the front attachments, rivet nut integrity
	09.05	Attachment bolts and stop nuts	Replace all the connection bolts/nuts and check proper closure torque. Add mark
	09.06	Attachments closure	Check all the attachments bolts and nuts previously opened, are re-closed at proper torque. Add mark
	09.07	Rudder hinge horn holes	Check all the hinge horn holes internal diameter, within 0.2 [mm] tolerance in respect of nominal bushing diameter
Rudder	10.07	Hinges	Replace all bolts, castle nuts with cotter pins and bushings of control surface
	10.08	Hinge horn holes	Check all the hinge horn holes internal diameter, within 0.2 [mm] tolerance in respect of nominal bushing diameter
Flight Control System	11.14	Joints	Replace all the bolts, stop nuts, castle nuts with cotter pins and bushings of control system joints, from stick/pedals to surfaces horns
	11.15	Flaperon mixer	Inspect all the rotating point, check the free play and correct function and installation of all the rotating points of the flaperon mixed and its horns / levers. Open each joint if necessary and lubricate properly
	11.16	Rudder pedals hinge	Check free play of plastic guides of rudder pedals hinge and if required close the bolts. Check wear and if necessary replace the plastics
Main landing gear	12.09	Axle	Open the teeth washer of wheel rim axle ring nut and check closure at proper torque, then re-close the teeth
	12.10	Main spring rubber	Replace the red rubbers (vulcolan) of main landing gear spring
Nose landing gear	13.12	Axle	Open the teeth washer of wheel rim axle ring nut and check closure at proper torque, then re-close the tooth
	13.13	Shock absorber	Replace bungee if not previously done
	13.14	End of run	Replace the end of run absorber (red vulcolan ring)

Table 22c



## MAINTENANCE MANUAL SAVANNAH S

<b>Doc. No.:</b>	MM-SVNH-EN
<b>Revision:</b>	07
<b>Rev. Date:</b>	07/11/2022
<b>Proj. Ref.:</b>	SVNH S

Structure / System	N°	Inspection item	Action / Description
Nose landing gear	13.15	Sliding plates	Replace lower plastic guides of the nose landing gear leg. Replace all the nuts (only), check proper torque closure and add mark
	13.16	Top plate	Check deformation of the top constrain plate and closure of the two bolt. If necessary, replace the top plate, bolts and add mark
Tail landing gear (if configured with)	13b.06	Tail spring	Replace the tail spring, bolts and stop nuts connection
	13b.07	Tail spring rubber	Replace the red rubber (vulcolan) pressing the tail spring
	13b.08	Hinges	Replace all bolts, castle nuts with cotter pins and bushings of the tail wheel steering control
Propeller	15.06	Hub bolts	Replace all the propeller hub bolts and nut. Check proper torque closure, add mark and safety wire where required
	15.07	Pitch setting and balancing	If changed blades pitch during hub disassembly, perform blades pitch setup and propeller balancing. Check propeller maximum speed on ground (and in-flight)
Engine	16.01	Engine Maintenance Manual	Apply manufacturer approved documentation for Maintenance
	16.19	Gearbox	Check the propeller gearbox with overload clutch (reduced at 600 hrs if used more than 30% of leaded fuel)
	16.20	Mount	Replace engine silent blocks. Replace all the connection bolts/nuts and check proper closure torque. Add mark
Powerplant controls	17.14	Throttle cables	Replace throttle bowden, terminals, cable, stop screw. Then, verify bowden ends connected to supports and safety wire locking aligned
Fuel system	18.16	Rubber hoses	Replace all the rubber hoses and their metal clamps in the powerplant area and below the fuselage (not inside of fuselage, excluding if it is evaluated necessary) then re-close. Check closure of metal clamp
	18.17	Vent	Replace all the fuel cups vent

Table 22d



## MAINTENANCE MANUAL SAVANNAH S

**Doc. No.:** MM-SVNH-EN

**Revision:** 07

**Rev. Date:** 07/11/2022

**Proj. Ref.:** SVNH S

Structure / System	N°	Inspection item	Action / Description
Fuel system	18.18	Collector tank	Drain fuel, then unscrew the draining valve and replace the internal o-ring (if any sign of leakage is present). Clean internally. When closing the valve, add fuel resistant Loctite 577
Water system	19.11	Rubber hoses	Replace all the rubber hoses and their metal clamps then re-close. Check closure of metal clamp
	19.12	Coolant	Flush coolant liquid
Oil system	20.16	Rubber hoses	Replace all the rubber hoses and their metal clamps then re-close. Check closure of metal clamp
Intake system	21.07	Air Filter	Replace air filter if not previously changed
Exhaust system	22.03	Muffler	Disassembly the muffler and seal all the manifolds. From the terminal tube add constant pressure and check for any point, around welding, where the air leaks, especially in the cabin heating chamber
Flight instrument	29.02	Altimeter	Check pressure setting and if needed perform altimeter calibration
	29.03	Vertical Speed Indicator	Check zero indication on ground and if needed perform calibration
	29.04	Compass	Check calibration and if needed perform calibration
	29.05	Reserve indicator	Drain the fuel with Collector tank draining valve and check that is activated the red warning reserve light about 3 centimetres below the top of Collector tank. If installed the 18lt Collector, monitor the level indicator and verify the reserve is highlighted at the third to fourth marks off; then entirely marks off when is empty
Flight check	27.11	Propeller speed	If changed blades pitch, check propeller maximum speed at full throttle, in levelled flight, 5550-5650 [RPM]. Check the correspondent setting at best rate of climb speed is about 5500 [RPM]

*Table 22e (a-e): 1000 [hrs] scheduled maintenance*

	<b>MAINTENANCE MANUAL SAVANNAH S</b>	<b>Doc. No.:</b> MM-SVNH-EN
		<b>Revision:</b> 07
		<b>Rev. Date:</b> 07/11/2022
		<b>Proj. Ref.:</b> SVNH S

#### 4.5. 2000 Hours maintenance checklist

The 2000 hours complete maintenance requires that a 1000 hours inspection has been carried out plus the tasks below stated.

Structure / System	N°	Inspection item	Action / Description
Fuselage	01.24	Tailplane attachments	Replace the front stabilizer attachment plates (ST072)
Right wing	02.13	Main spar attachment plate	Replace the attachment plate
	02.14	Front strut attachment plates	Replace the strut attachment
	02.15	Strut fork	Replace all the struts forks and reassembly with new bolts and nuts
	02.16	Flaperon horns	Replace flaperon horns and its reinforcement angles (SA084, SA068 and SA069)
Right Flaperon	03.08	Connection plates	Replace the connection plates between the inboard and outboard Flaperon (SC021, SC024). Replace the bolt and stop nut. Distance between flaperon trailing edge must be 18 [mm]
Left wing	04.17	Main spar attachment plate	Replace the attachment plate
	04.18	Front strut attachment plates	Replace the strut attachment
	04.19	Strut fork	Replace all the struts forks and reassembly with new bolts and nuts
	04.20	Flaperon horns	Replace flaperon horns (SA084, SA068 and SA069)
Left Flaperon	05.08	Connection plates	Replace the connection plates between the inboard and outboard Flaperon (SC021, SC024). Replace the bolt and stop nut. Distance between flaperon trailing edge must be 18 [mm]
Stabilizer	06.09	Attachments	Check forward attachment plates ST401, ST402 within tolerance of 0.2 [mm] in respect of nominal bolt diameter. Replace rear attachment plates (ST405, ST406, ST407)
		Elevator hinge horns	Replace hinges support plates SD020, SD024 and SD025
	06.11	Fin attachment	Replace front fin attachment plate ST409
Elevator	07.09	Elevator hinge tip bolt	Replace the elevator hinge bolt riveted at the tip (SE040)

Table 23a





## MAINTENANCE MANUAL SAVANNAH S

<b>Doc. No.:</b>	MM-SVNH-EN
<b>Revision:</b>	07
<b>Rev. Date:</b>	07/11/2022
<b>Proj. Ref.:</b>	SVNH S

Structure / System	N°	Inspection item	Action / Description
Elevator	07.10	Elevator hinge horns	Replace hinges angle (SA087-2)
	07.11	Elevator control system horns	Replace the control system horns (SE028, SE029)
Trim Tab	08.04	Trim control	Replace the push-pull rods and uniball
	08.05	Trim actuator	Check the actuator lever without cracks or local deformation when push-pull rod has been disassembled. If any problem observed, replace the actuator
Vertical Tail (Fin)	09.08	Attachments	Check front spar with its attachment and rivnuts. Check rear spar with attachment holes within tolerance of 0.2 [mm] in respect of the nominal bolt diameter
	09.09	Rudder hinge	Replace all the rudder hinge horns SG013 and SG010 (which is on fuselage assembly)
Rudder	10.09	Hinge horns	Replace all the rudder hinge horns (SA087-3, SA087-4)
	10.10	Control system horn	Check the rudder control system horn plate holes within tolerance of 0.2 [mm] in respect of the nominal bolt diameter (ST508)
Flight Control System	11.17	Pulley	Replace the cables pulley, its safety cotter pins and bolts/nuts
	11.18	Cables	Replace the control cables and bulkhead fairleads
	11.19	Joints	Replace all the bushings and bearings of control system joints. Replace all the push-pull rod uniball including the ones of steering
	11.20	Torque tube	Replace the torque tube front aluminium bushing and the rear plastic bushing
Main landing gear	12.11	Spring bolts	Replace the spring fixing bolts and nuts
	12.12	Bearings	Replace wheels bearings
	12.13	Brake discs	Replace brake discs
	12.14	Oil brakes	Bleeds and change oil brakes
Main landing gear tail dragger (if configured with)	12b.02	Brace rods	Replace the brace rods, uniball and connecting bolts/nuts

Table 23b

	<b>MAINTENANCE MANUAL SAVANNAH S</b>	<b>Doc. No.:</b> MM-SVNH-EN
		<b>Revision:</b> 07
		<b>Rev. Date:</b> 07/11/2022
		<b>Proj. Ref.:</b> SVNH S

Structure / System	N°	Inspection item	Action / Description
Tail landing gear (if configured with)	13b.09	Steering cables	Replace tail wheel steering control cables and springs. Replace all the joint bushings, bolts and nuts
Propeller	15.01	Propeller Maintenance Manual	Apply manufacturer approved documentation for Maintenance
	15.08	Overhaul	Propeller overhaul
Engine	16.01	Engine Maintenance Manual	Apply manufacturer approved documentation for Maintenance
	16.21	Overhaul	Engine overhaul
Fuel system	18.19	Wing tank cup	Replace the fuel tanks cup support o-ring. Replace the cups o-ring
	18.20	Wing tanks	Clean the tank internally
	18.21	Collector tank	Clean the tank internally
	18.22	Auxiliary fuel pump	Replace the auxiliary fuel pump
	18.23	Hoses	Replace all the rubber hoses with metal clamp, including the ones installed in the wing and fuselage
Cabin heating	23.03	Hot air pipes	Replace SCAT pipes of cabin heating

Table 23c (a-c): 2000 [hrs] scheduled maintenance



# MAINTENANCE MANUAL SAVANNAH S

Doc. No.:	MM-SVNH-EN
Revision:	07
Rev. Date:	07/11/2022
Proj. Ref.:	SVNH S

## 5. Unscheduled Maintenance

The unscheduled maintenance is comprehensive of all the actions not foreseen during the regular maintenance schedule. Some unusual intervention are known and therefore described in the subchapters below. For different cases, where the maintenance work and procedure is not clear or when the structure is affected, contact the manufacturer of the aircraft or equipment affected.

### WARNING

Unscheduled maintenance can seriously affect the safety of flight and occupants. If the maintenance action is not already described below or there are any discrepancies or doubt about the description, always contact the manufacturer to establish the correct maintenance action, procedure and parts to replace

### 5.1. Heavy landing

Control the aircraft before the next flight.

#### Main landing gear:

Verify the landing gear spring shape and integrity, the attachments area, the fuselage surrounding areas, the spring constrain brackets and its bolts, red rubber (Vulcolan), wheel rims, tyres, wheel axis and its ring nut closure. For any problem observed, replace the part damaged with a spare new one. If the main landing gear spring is bent abnormally or unsymmetrically (within a certain limits, about 15° from the design), it is possible to disassemble the spring and bent again to the correct design values by means of bending machine or hydraulic press with internal radius of 110 [mm] and external . Design values (without any constrains or loads/weight) are the following, with +/- 5° and +/- 50 [mm] of tolerance:

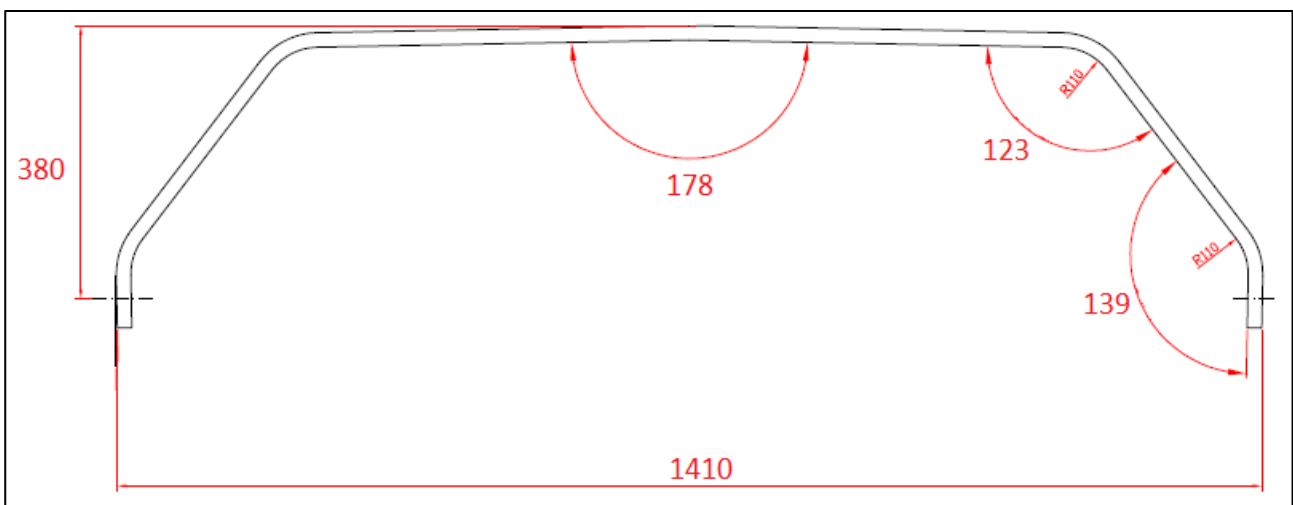

Figure 10: Main landing gear spring design nominal dimensions (unloaded)

	<b>MAINTENANCE MANUAL SAVANNAH S</b>	<b>Doc. No.:</b> MM-SVNH-EN
		<b>Revision:</b> 07
		<b>Rev. Date:</b> 07/11/2022
		<b>Proj. Ref.:</b> SVNH S

Nose landing gear:

Verify the nose landing gear leg and attachment plate shape, welding, bolts, the fork shape and wheel axis, the axis bolts closure, its safety wire, the ring nut closure. Verify also the lower and upper leg constrains, with plastic guide, the supporting structure, the Vulcolan end of run, the steering rod and uniball, check rudder pedals and hinges. Verify the wheel rim and tyre.

For any problem observed, replace the part damaged with a spare new one.

## 5.2. Fuel system leakage in fuselage

When observed fuel in fuselage, find the source, drain the fuel if required, clean the humid area and replace the parts affected by the problem. Open all the possible inspection port and let the liquid evaporate and vapour eliminate. Check all the fuel system connections and perform a pressure test at 0.3 [bar]. Verify that no additional parts are damaged or corroded by the fuel.

## 5.3. Wing tank or cup fuel leakage

When observed leakage from wing tank compartment, open the inspection panel and find the source, drain the fuel if required, clean the humid area and replace the parts affected by the problem. If the leakage comes from the tank support, replace the entire tank. If the leakage comes from a tank fuel fitting, installed directly on the tank, replace the fitting, check if the tank hole is capable to support a new fitting and add sufficient sealant (fuel resistant). If the leakage comes from the cup ring (socket), verify that the o-ring is correctly installed between the tank and the ring, the ring is not unscrewed. If this problem occur, replace the entire fuel tank or replace the o-ring adding sufficient sealant, verifying o-ring positioning during the ring closure.

Verify the cup has the o-ring intact.

## 5.4. Radiator suspension breakage

If radiator bracket or silent-block are broken, replace the parts. Pay attention to the installation position by verifying the relative position with the engine cowling.

## 5.5. Windshield or window cracks or breakage

If a Lexan window is broken or cracked more than 25 [mm], replace entirely. If observed a new crack within the previous limit, stop the crack making a hole of 1 [mm] diameter at the end of the crack.

	<b>MAINTENANCE MANUAL SAVANNAH S</b>	<b>Doc. No.:</b> MM-SVNH-EN
		<b>Revision:</b> 07
		<b>Rev. Date:</b> 07/11/2022
		<b>Proj. Ref.:</b> SVNH S

## 5.6. Object strike the structure

If an object strikes on the wing skin, especially in the leading edge, or in the tailplane, verify the absence of cracks and measure the depth of deformation: the acceptable limits must be evaluated in function of the interested area and generally could be maximum about 5 [mm] depth in a damaged area of 50 [mm] of diameter. Damages to the reinforcement (spar, stringers, bulkhead) of the structure are not acceptable.

### WARNING

**Damages of aerodynamic surfaces larger than tolerances given, can lead to flight safety issue or death. For any doubt, contact the manufacturer even for a maintenance ferry flight.**

## 5.7. Propeller strike

When propeller strikes on ground, apply the propeller manufacturer maintenance manual or contact them directly. As a general consideration, if the propeller is intact in the all the blades shape, verify the propeller pitch setting and perform the propeller balance. If the engine has stop during the propeller strike, apply the engine manufacturer maintenance manual.

## 5.8. Engine failure

Apply the engine manufacturer maintenance manual and all the required verifications. Check all the system connected to the engine: induction, oil, cooling,

## 5.9. Engine parameter exceeding

Of any of the engine parameter has been exceeded, apply the relevant section of the manufacturer maintenance manual.

## 5.10. Noncompliance with fuel quality

Drain entirely the fuel, fill with 10 [lt] of correct fuel, switch on the auxiliary pump for few minutes and then drain again. Verify the fuel tank are not deformed and check no leakage occurs in any point of the fuel system. Apply also the engine maintenance manual at the relevant chapter.

## 5.11. Noncompliance with engine fluid quality

Apply the engine maintenance manual at the relevant chapter.

	<b>MAINTENANCE MANUAL SAVANNAH S</b>	<b>Doc. No.:</b> MM-SVNH-EN
		<b>Revision:</b> 07
		<b>Rev. Date:</b> 07/11/2022
		<b>Proj. Ref.:</b> SVNH S

### 5.12. Noncompliance with brake oil quality

If used DOT fluid (wrong), bleed all the oil from brakes caliper, add some Mineral oil in the pedal pumps, bleed also the mineral oil from the brakes caliper. Replace the brakes caliper piston quad-ring and the pumps o-ring set with spare new ones. Add new mineral oil and purge the entire system, add oil up to the adequate level in the pumps and verify no air bubble are present in the lines.

### 5.13. Electric circuit overload (breaker out)

Follow the line of the circuit breaker which has gone out and search for a problem, short circuit, terminals disconnected, not protected or insulated wire, load or electric utility damaged, in short circuit, or actuator locked (i.e. flaps). When the problem is identified, try to reconnect the circuit breaker and check if the function works properly without any additional problem or hazard for the airplane.

### 5.14. Flight envelope exceeding

If any flight envelope or operational limitation not below described has been exceeded, contact the manufacturer.

#### 5.14.1. Airspeed exceeding

If the maximum airspeed ( $V_{ne}$ ) has been exceeded for more than 15 seconds and at more than 250 km/h (IAS), verify all the structure and attachments of the wing, struts and tailplane, verify also the control system lines, surfaces, joints, hinges, support horns and control horns. If any parts are not regular, contact the manufacturer of the airplane.

#### 5.14.2. Airspeed exceeding with high turbulence

If the maximum normal operation airspeed ( $V_{no}$ ) has been exceeded for more than 15 seconds and at more than 200 km/h (IAS), verify all the structure and attachments of the wing, struts and tailplane, verify also the control surfaces structure, shape, hinges, support horns and control horns. If any parts are not regular, contact the manufacturer of the airplane.

#### 5.14.3. Load factor exceeding

If the maximum load factor has been exceeded for more than 5 seconds and at more than 5 g's (alternatively a strong full stick pull-up or down at 15 km/h more than manoeuvring speed, about 150 km/h), verify all the structure and attachments of the wing, struts and tailplane, verify also the control

	<b>MAINTENANCE MANUAL SAVANNAH S</b>	<b>Doc. No.:</b> MM-SVNH-EN
		<b>Revision:</b> 07
		<b>Rev. Date:</b> 07/11/2022
		<b>Proj. Ref.:</b> SVNH S

system lines, surfaces, joints, hinges, support horns and control horns. If any parts are not regular, contact the manufacturer of the airplane.

#### 5.14.4. Flap overspeed

If the maximum full-flap operation airspeed ( $V_{fe}$ ) has been exceeded for more than 15 seconds and at more than 135 km/h IAS (alternatively, if only with half-flap extended, at more than 145 km/h), verify all the flaperon structure (shape and surfaces), attachment horns and lateral control system, joints, hinges and control horns. If any parts are not regular, contact the manufacturer of the airplane.

#### 5.14.5. Take-off mass exceeding

If the maximum take-off mass has been exceeded at more than 650 [kg] in combination with observed turbulence in flight or load factor reached major than 3.8 g's, verify all the structure and attachments of the wing, struts and tailplane, verify also the control system lines, surfaces, joints, hinges, support horns and control horns. If any parts are not regular, contact the manufacturer of the airplane.

	<b>MAINTENANCE MANUAL SAVANNAH S</b>	Doc. No.: MM-SVNH-EN
		Revision: 07
		Rev. Date: 07/11/2022
		Proj. Ref.: SVNH S

**Left intentionally blank**



	<h1 style="color: blue; margin: 0;">MAINTENANCE MANUAL SAVANNAH S</h1>	Doc. No.: MM-SVNH-EN
		Revision: 07
		Rev. Date: 07/11/2022
		Proj. Ref.: SVNH S

## 6. Aircraft and Systems description

### 6.1. Airframe

The *Savannah<sup>TM</sup> S* is a monoplane with a high braced wing, two seat side-by-side airplane. The airframe is mainly composed of aluminium alloy AL-6061-T6 which has self anti corrosion characteristics. Additional protection is done in the area of metal sheet overlapping, which are protected by the application of a thin layer of primer paint. The welded parts are made of steel 25CrMo4 or AISI-304. High stress parts such as the main landing gear spring are made of aluminium alloy AL-7075-T4. The fuselage is composed of two sections (front and rear) with bulkheads and reinforcement stringers joined by rivets and solid rivets. The firewall is made of galvanized steel plate and the seats are an integral part of the cabin structure. Welded Steel tube cabin frame is used to hold wing attachment points and support forward fuselage loads. The wing airfoil is designed to generate high lift and the wing adopts Junkers type flaperon (aileron + flap) to improve manoeuvrability at low speed. The wings are rectangular in plan with small dihedral and without washout. A “virtual washout” is introduced by different angle between inboard and outboard flaperons. Wing structure is composed of main and aft spars with a torque box. Two wing struts are connecting the wing and the fuselage. Horizontal Tail plane is composed of stabilizer and elevator with anti-balance electric trim tab. Vertical tailplane is composed of conventional fin and rudder. Horizontal tailplane is bolted to the aft fuselage with four attachment points of the stabilizer. The vertical tailplane is then connected to the stabilizer and to the rear fuselage cone with six fin bolts. The engine mount is made of two parts, a inner ring and a fuselage mount, composed of steel 25CrMo4 welded tubes. The two parts are bolted together with silent-blocks in order to dampen engine vibrations.

A complete description of the structures and parts are given in the dedicated *Construction Manual*, with related *Spare Parts Catalogue*, which are already indicated in the *Chapter 1.2*.

Follow few images of the aircraft main structure composition and stiffeners, exploded views. All the reference numbers (round marks) are related to the Part Numbers shown only in the dedicated tables of the *Spare Parts Catalogue*.



# MAINTENANCE MANUAL SAVANNAH S

Doc. No.: MM-SVNH-EN

Revision: 07

Rev. Date: 07/11/2022

Proj. Ref.: SVNH S

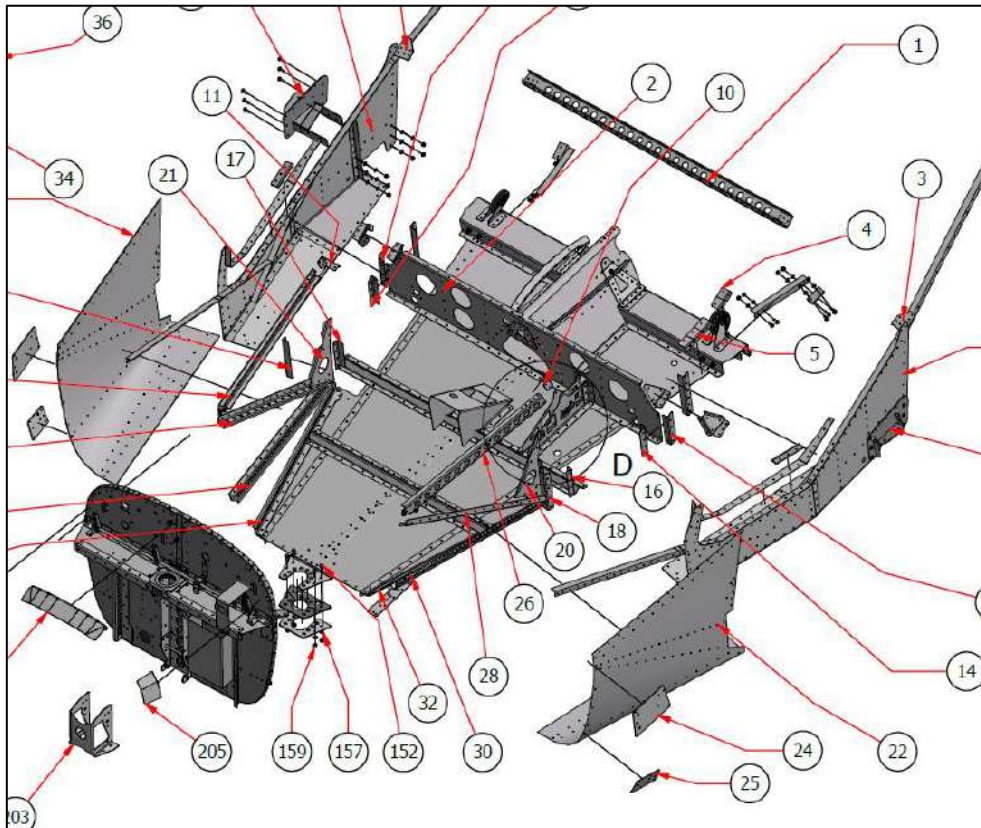

Figure 11: Cabin floor

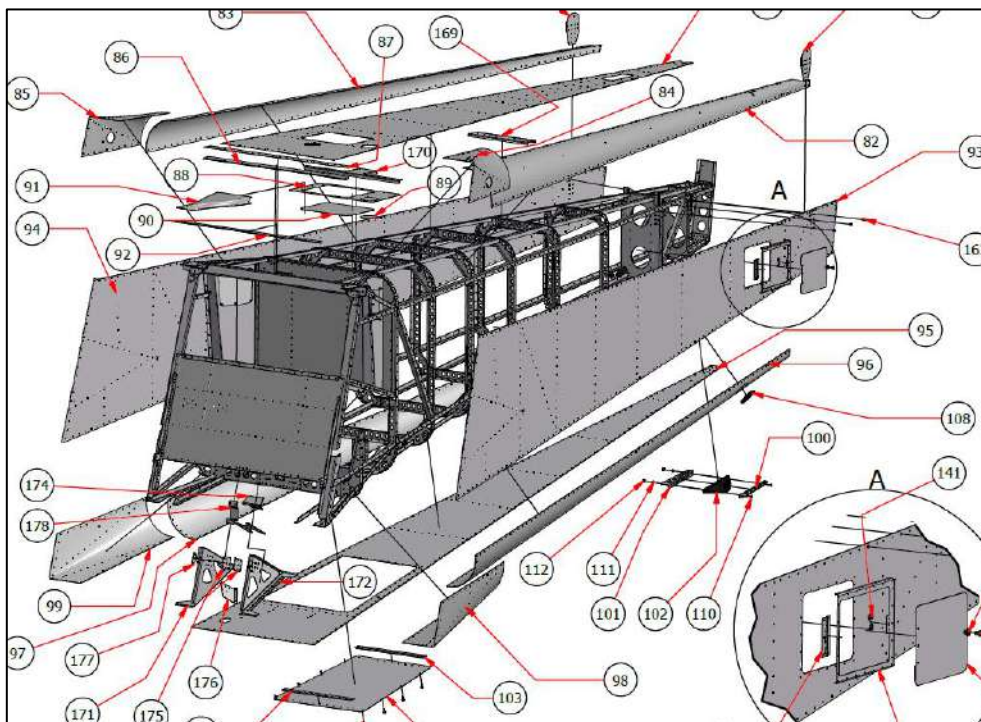

Figure 12: Fuselage rear cone



# MAINTENANCE MANUAL SAVANNAH S

Doc. No.: MM-SVNH-EN

Revision: 07

Rev. Date: 07/11/2022

Proj. Ref.: SVNH S

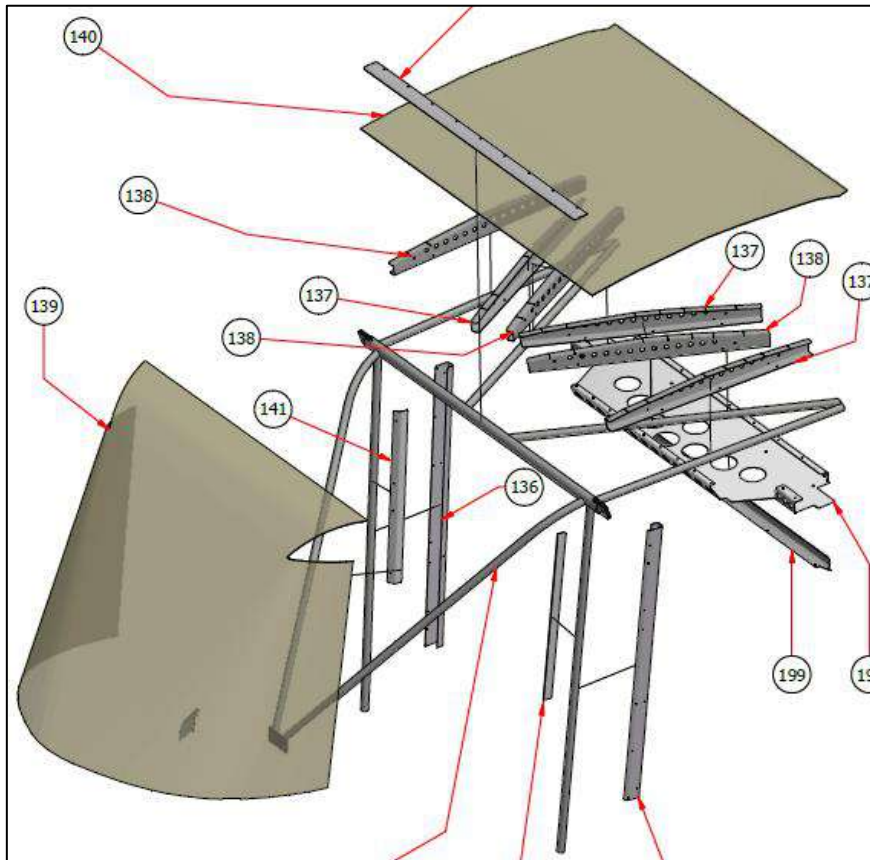

Figure 13: Cabin frame and windshield

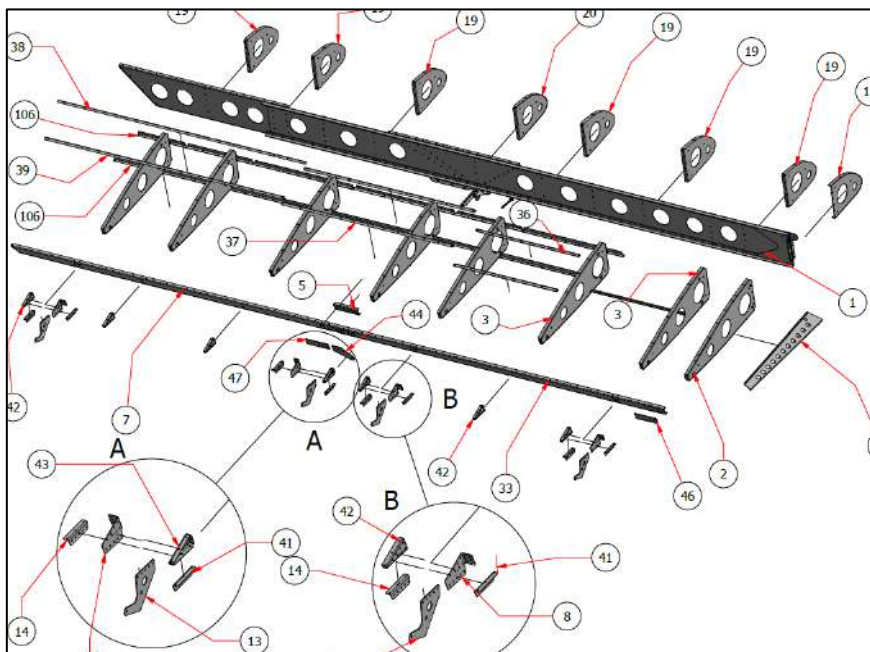

Figure 14: Left wing



# MAINTENANCE MANUAL SAVANNAH S

Doc. No.: MM-SVNH-EN

Revision: 07

Rev. Date: 07/11/2022

Proj. Ref.: SVNH S

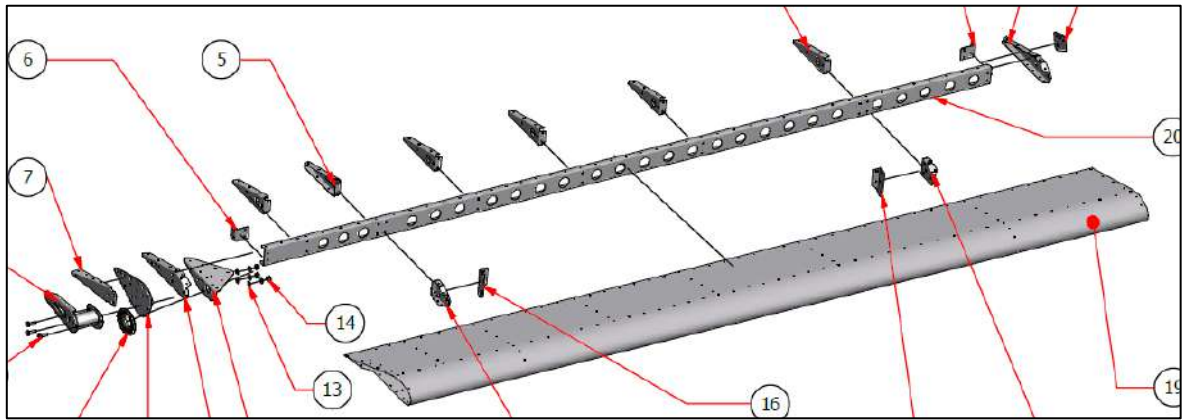

Figure 15: Left inboard flaperon

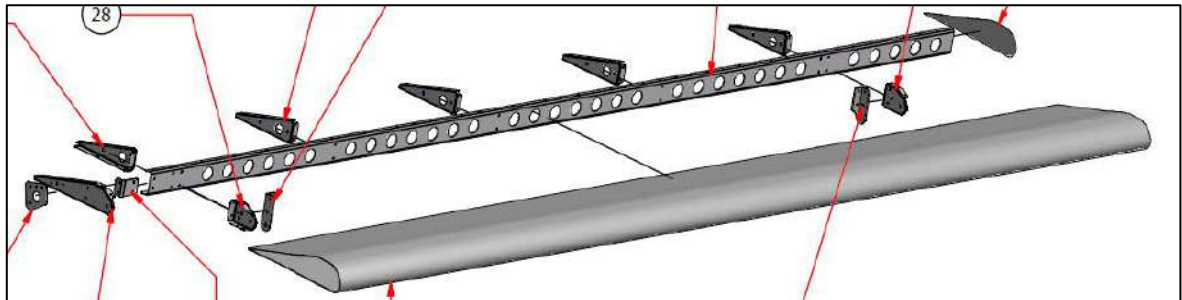

Figure 16: Left outboard flaperon

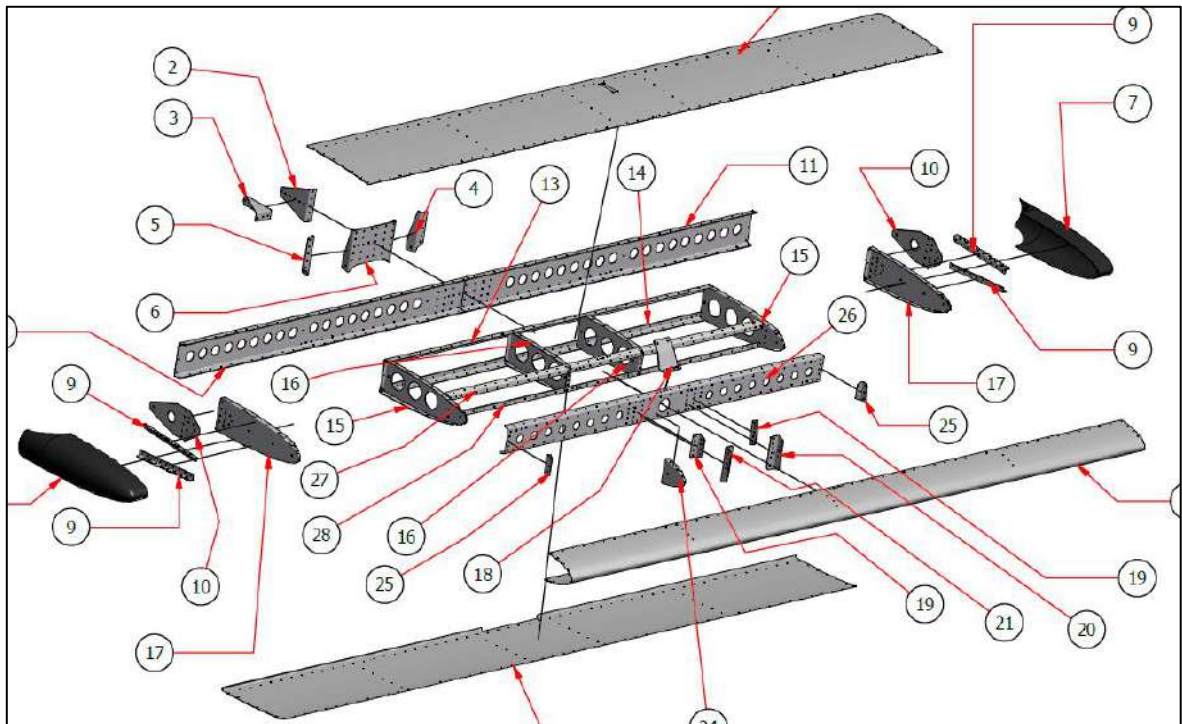

Figure 17: Stabilizer



# MAINTENANCE MANUAL SAVANNAH S

Doc. No.: MM-SVNH-EN

Revision: 07

Rev. Date: 07/11/2022

Proj. Ref.: SVNH S

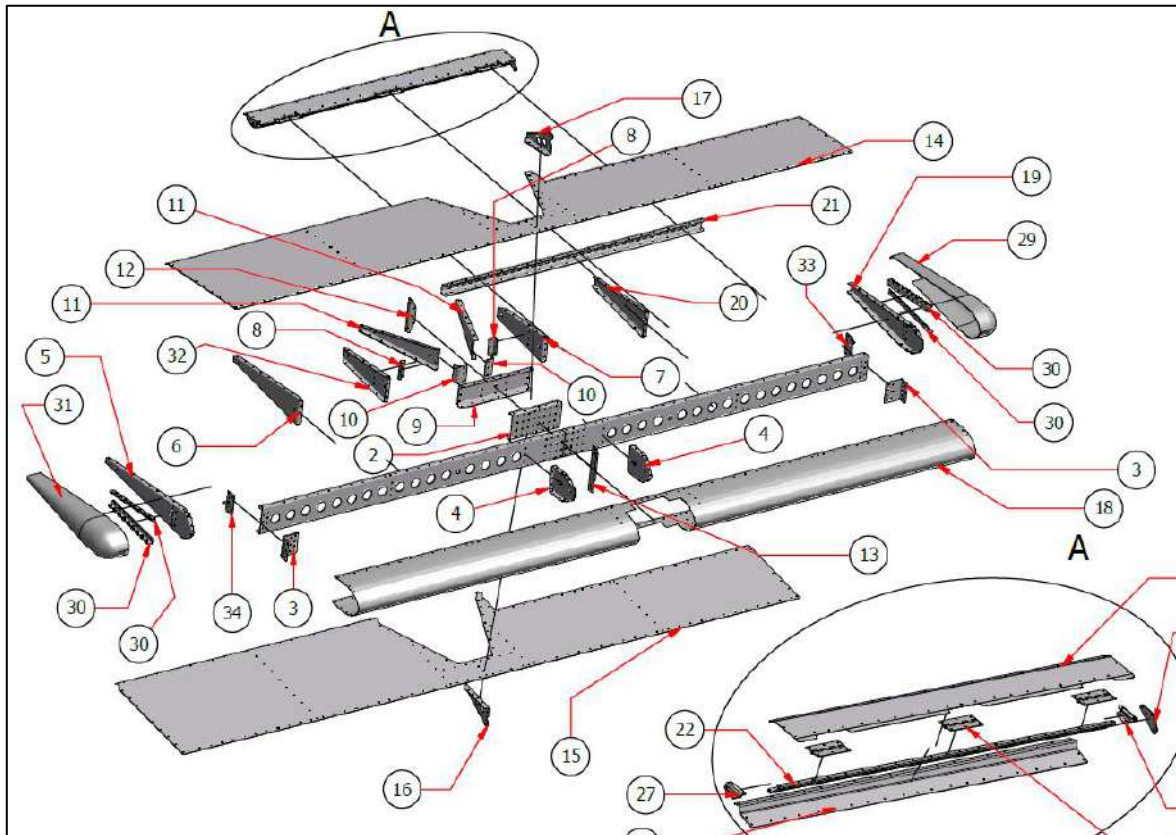

Figure 18: Elevator

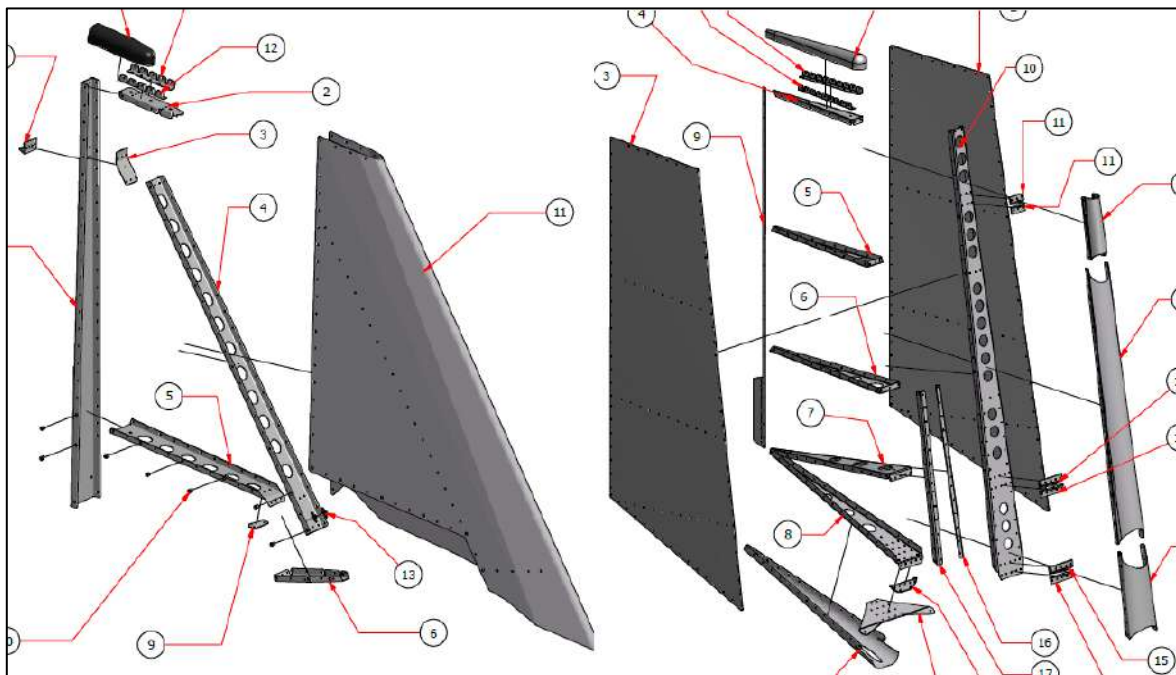

Figure 19: Fin and Rudder



# MAINTENANCE MANUAL SAVANNAH S

Doc. No.: MM-SVNH-EN

Revision: 07

Rev. Date: 07/11/2022

Proj. Ref.: SVNH S

## 6.2. Controls

**LONGITUDINAL:** the Elevator is connected to a central stick (dual control stick is optional) by means of an initial push-pull rod with levers where are connected cables for the second section up to the elevator central horn. Deflections are approximately +/- 25°.

**LATERAL:** the Flaperon are connected entirely by means of push-pull rod, which +/-15.5° of rotation. The flap function is assured by the mechanical mixer shown in *Figure 20*, with 27° of down rotation.

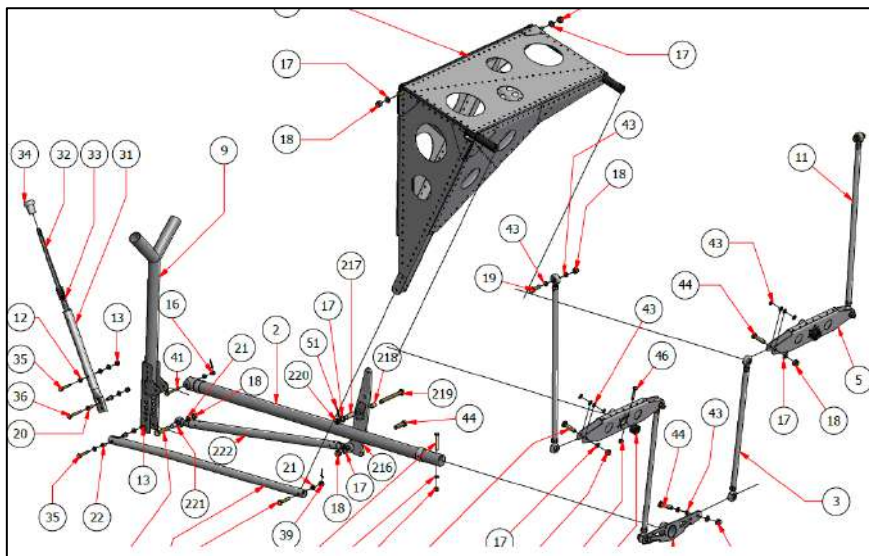

Figure 20: Longitudinal and lateral controls

**DIRECTIONAL:** the rudders (+/- 28° of rotation) is connected by means of cables to the pedals, useful also for the ground steering function. Brakes pedals are installed in the top of rudder pedals.

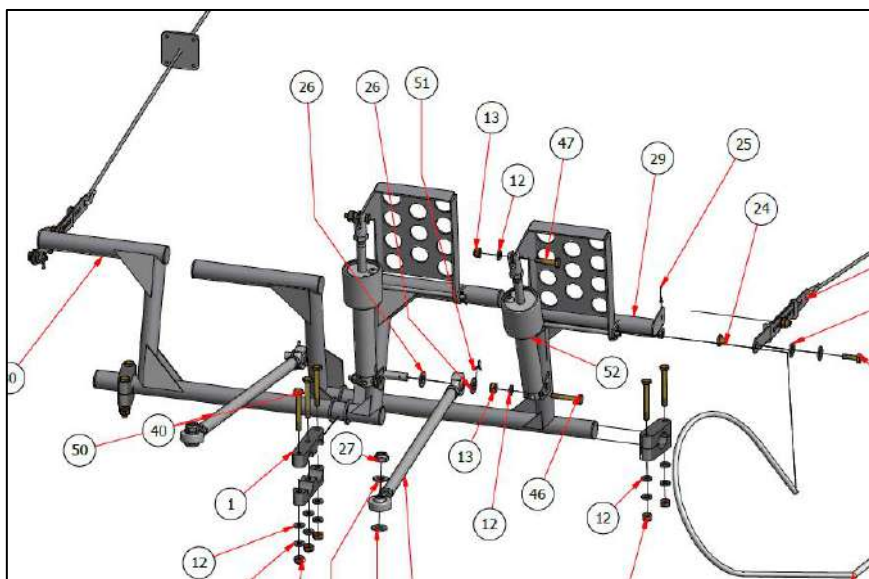

Figure 21: Directional controls

	<b>MAINTENANCE MANUAL SAVANNAH S</b>	<b>Doc. No.:</b> MM-SVNH-EN
		<b>Revision:</b> 07
		<b>Rev. Date:</b> 07/11/2022
		<b>Proj. Ref.:</b> SVNH S

## 6.3. Powerplant

### 6.3.1. Engine

Follows the installable engine list and their specifications.

Manufacturer	BRP-Rotax GmbH & Co KG		
Model	912 UL	912 ULS / S	912 iS
Type	Four horizontal opposed cylinder, aspirated with carburettor		Four horizontal opposed cylinder, aspirated with injection
Displacement	1211 [cm <sup>3</sup> ]	1352 [cm <sup>3</sup> ]	
Maximum take-off power	80 [hp] (59.6 kW) @ 5800 RPM	100 [hp] (73.5 kW) @ 5800 RPM	
Maximum continuous power	78 [hp] (58 kW) @ 5500 RPM	92 hp (69 kW) @ 5500 RPM	
Gear reduction ratio	2.27	2.43	
Inner cylinder cooling	Air		
Head cooling	Liquid		
Engine EASA TCDS	E.121		
Engine ASTM CoC	ASTM F2339-17 Compliance Statement FB 16-012-1/Q		

Table 24: Engines

### 6.3.2. Propeller

Follows the installable propellers list and their specifications.

Manufacturer	Model	Type	Diameter
DUC Hélices	Swirl, Swirl-R, Swirl-L, Swirl-3, Swirl-3L	On-ground variable pitch, 3 blades, carbon fiber	1730 [mm]
DUC Hélices	Flash, Flash-R, Flash-3, Flash-3-R, Flash-L, Flash-3-L	On-ground variable pitch, 3 blades, carbon fiber	1750 [mm]
E-PROPS	Durandal, V20	On-ground variable pitch, 3 blades, carbon fiber	1750 [mm]
E-PROPS	Glorieuse	Variable pitch, 3 blades, carbon fiber	1750 [mm]
Ivoprop	Patriot	Variable pitch, 3 blades, carbon fiber	1780 [mm]

Table 25. Propellers



# MAINTENANCE MANUAL SAVANNAH S

Doc. No.: MM-SVNH-EN

Revision: 07

Rev. Date: 07/11/2022

Proj. Ref.: SVNH S

## 6.4. Fuel system

Follows the layout of the fuel system.

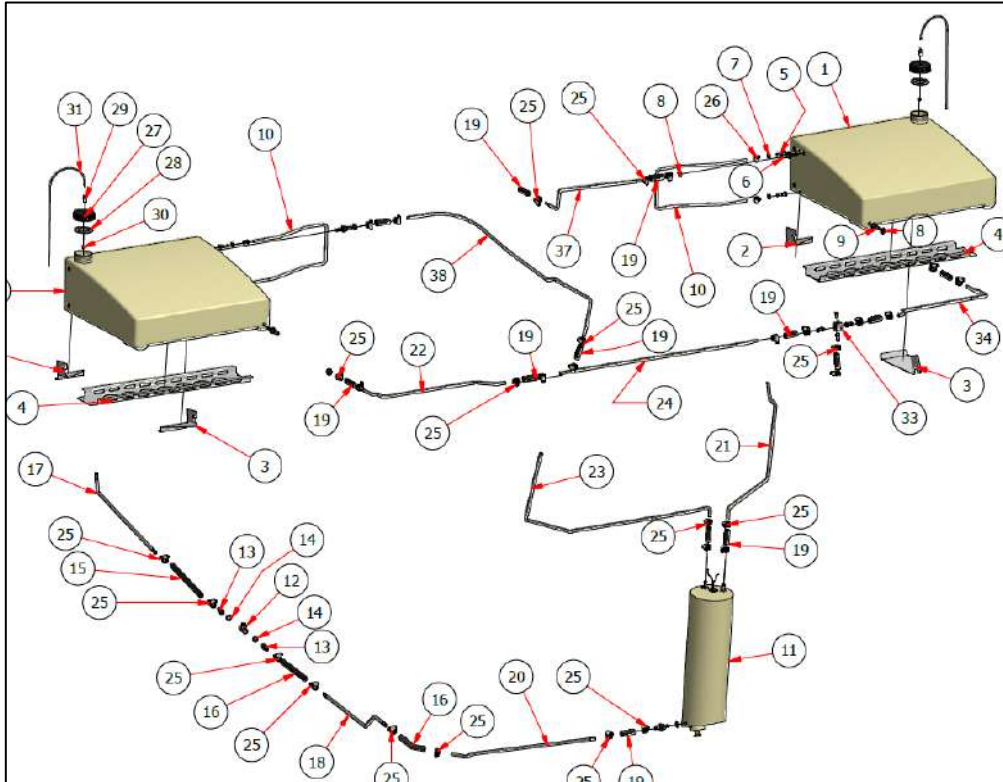

Figure 22: Airframe fuel system parts

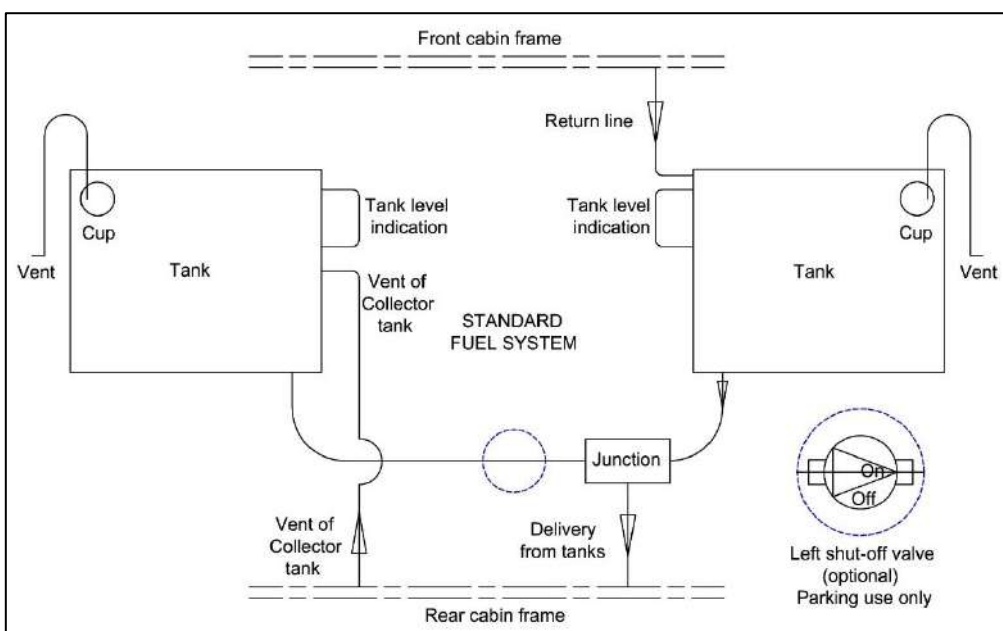

Figure 23: Wing standard fuel system





# MAINTENANCE MANUAL SAVANNAH S

Doc. No.: MM-SVNH-EN

Revision: 07

Rev. Date: 07/11/2022

Proj. Ref.: SVNH S

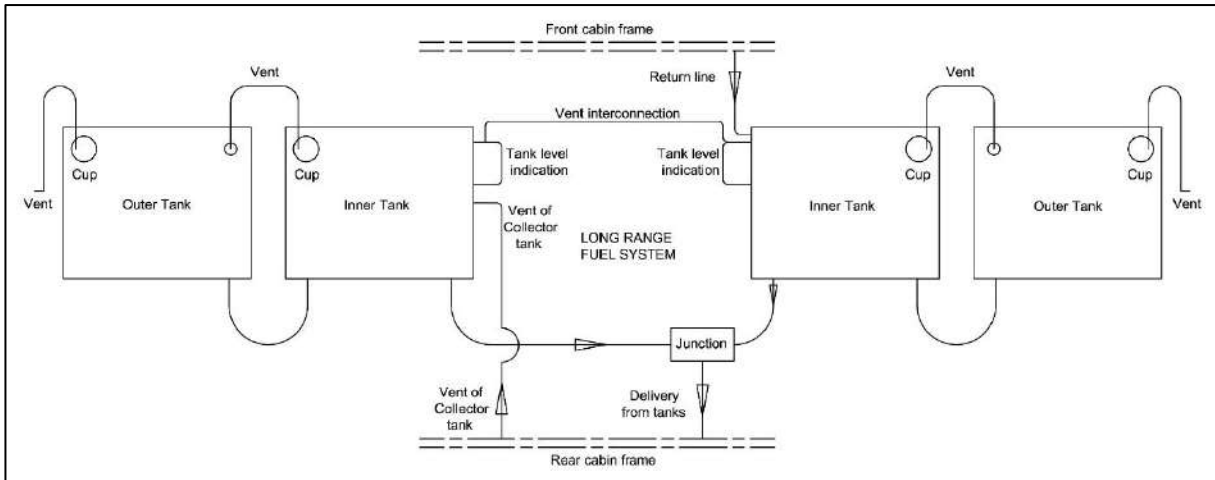

Figure 24: Wing double fuel tank system (interconnected tanks)

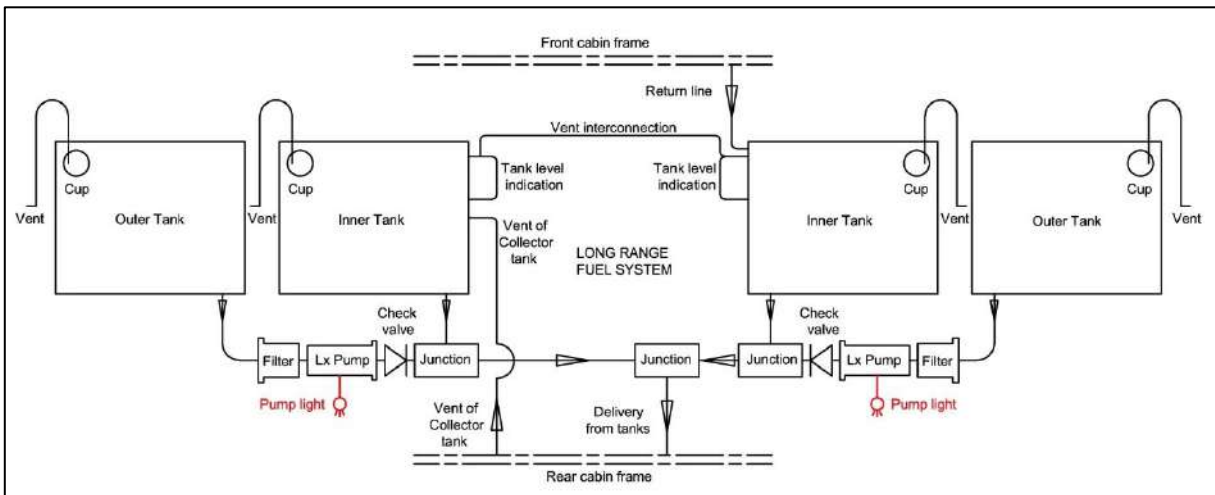

Figure 25: Wing double fuel tank system with transfer pumps

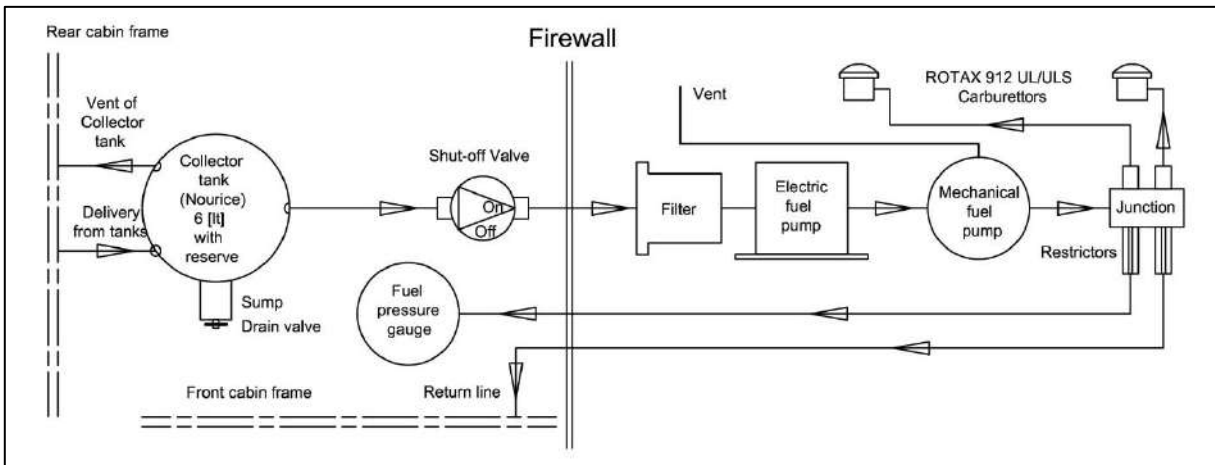

Figure 26: Fuselage and Rotax 912 UL/ULS fuel system



# MAINTENANCE MANUAL SAVANNAH S

Doc. No.: MM-SVNH-EN

Revision: 07

Rev. Date: 07/11/2022

Proj. Ref.: SVNH S

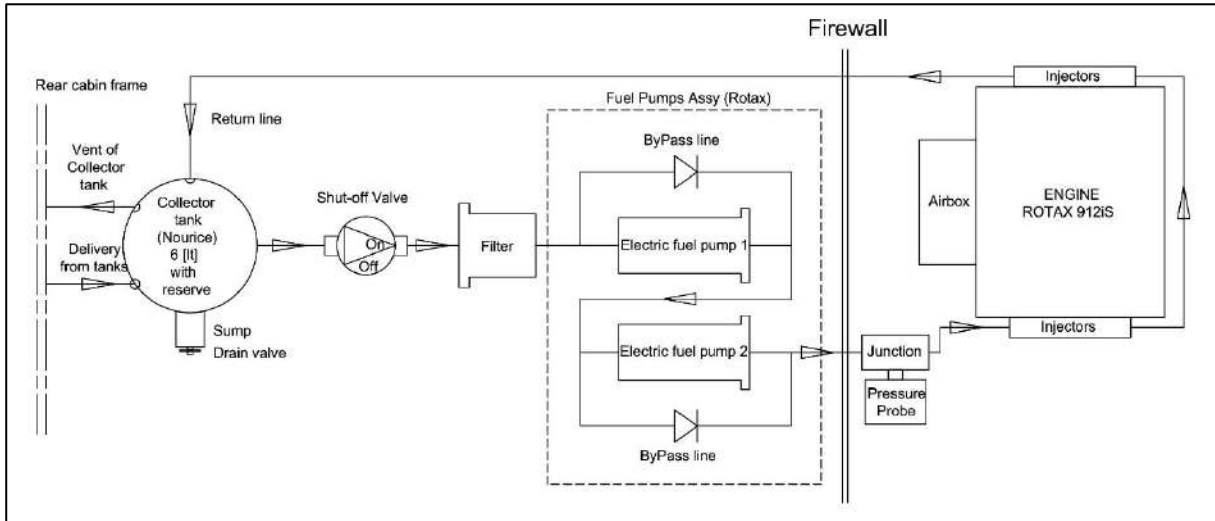

Figure 27: Fuselage Rotax 912 iS fuel system

The fuel system volumes are the following:

Tank	Total capacity [lt]	Fuel volume [lt]	Not usable [lt]
Wing tanks (standard)	2x36 = 72	2x35 = 70	2x0.5 = 1
Double wing tanks (optional)	4x36 = 144	4x35 = 140	4x0.5 = 2
Collector tank 6 (standard)	6	6	0
Collector tank 18 (optional)	18	18	0
Draining sump	N/A	0.25	0.25
Lines	N/A	0.5	0.5

Table 26: Fuel system volumes

## 6.5. Oil system

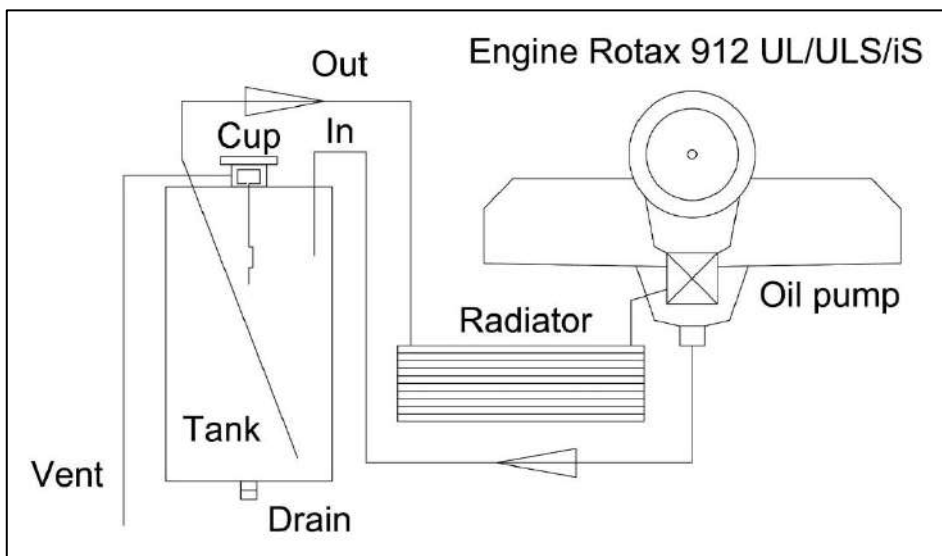

Figure 28: Rotax 912 UL/ULS/iS standard oil system



# MAINTENANCE MANUAL SAVANNAH S

Doc. No.: MM-SVNH-EN

Revision: 07

Rev. Date: 07/11/2022

Proj. Ref.: SVNH S

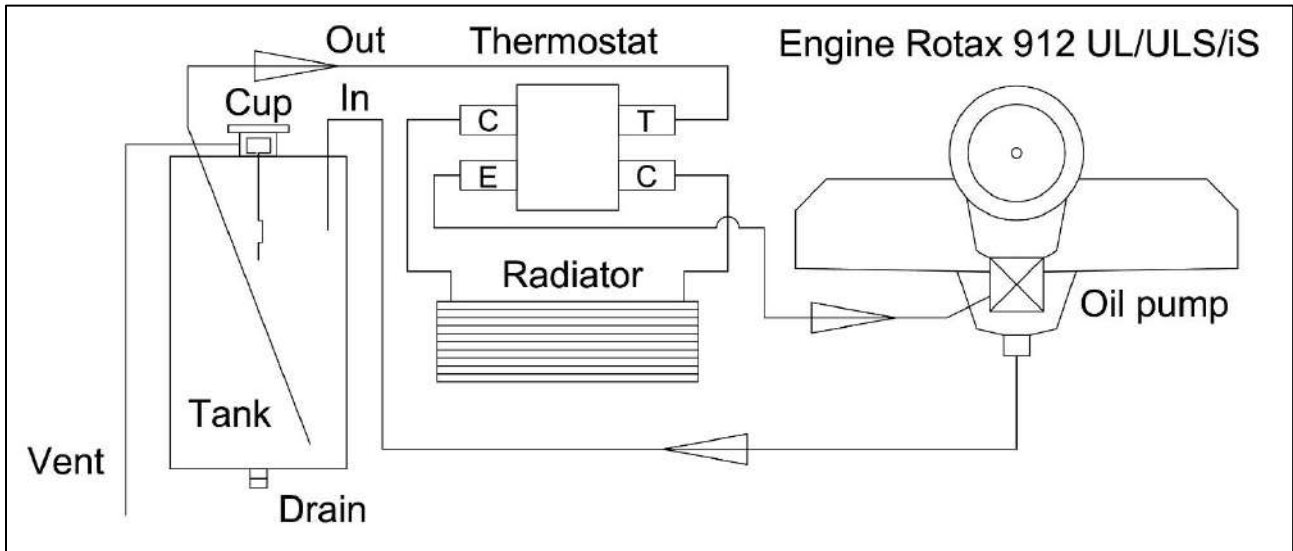

Figure 29: Rotax 912 UL/ULS/iS oil system with thermostat

Item	Capacity [lt]
Oil tank	2.5 - 3
Lines and radiator	0.5
TOTAL	3.5

Table 27: Oil system capacity

## 6.6. Cooling system

Follows cooling system layout.

Item	Capacity [lt]
Expansion tank, engine and pump	$0.25+0.56+0.1 = 0.91$
Overflow bottle	0.5
Lines and radiator	0.6
TOTAL	2

Table 28: Cooling system capacity



# MAINTENANCE MANUAL SAVANNAH S

Doc. No.: MM-SVNH-EN

Revision: 07

Rev. Date: 07/11/2022

Proj. Ref.: SVNH S

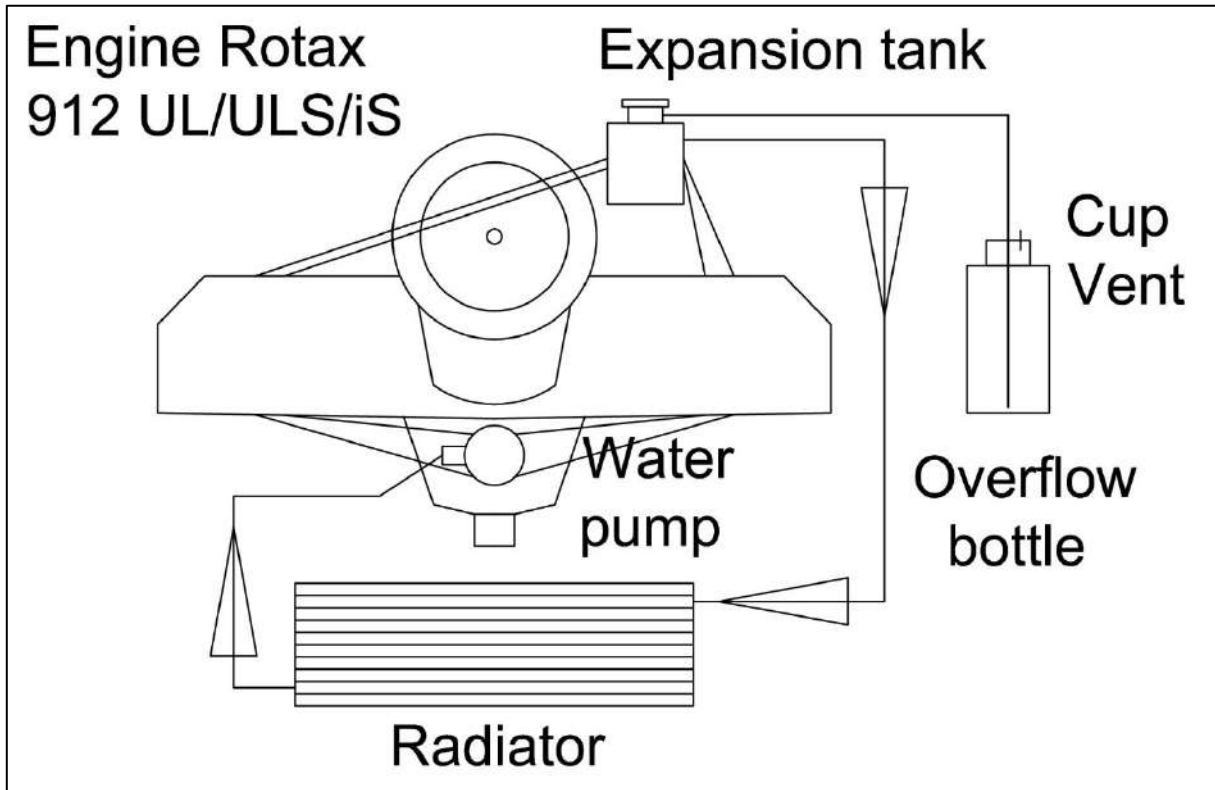

Figure 30: Rotax 912 UL/ULS/iS standard cooling system

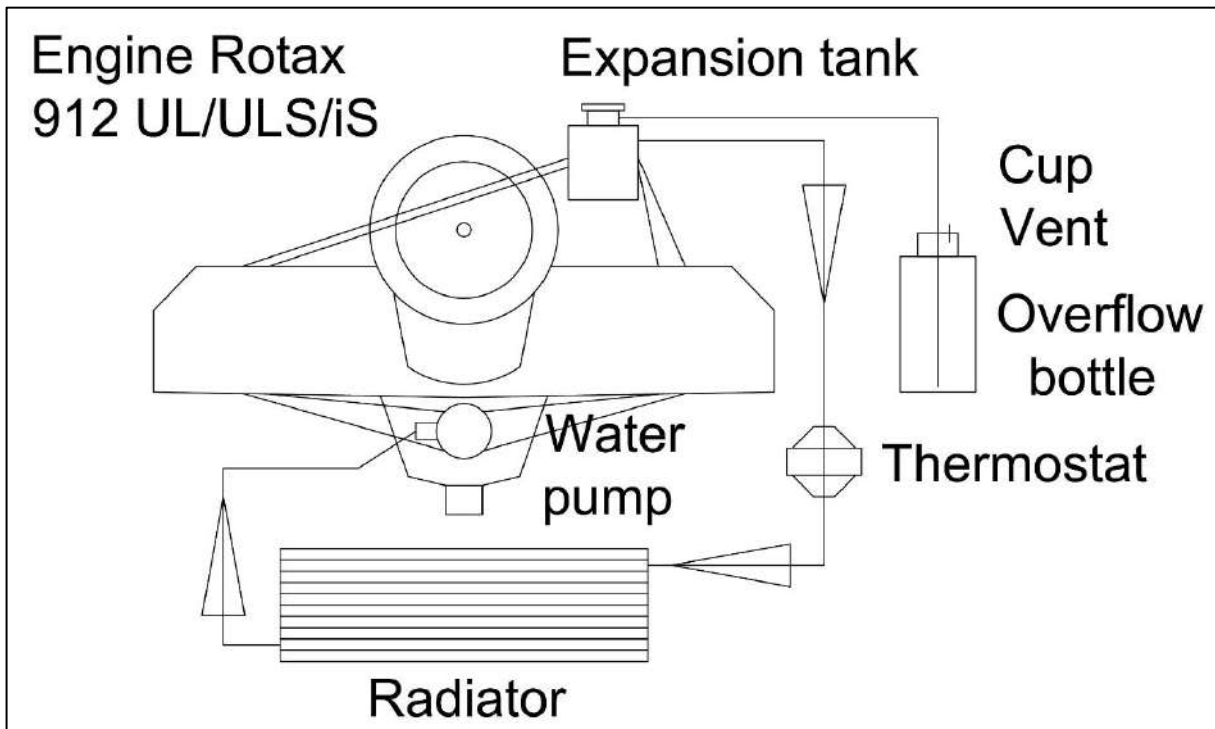

Figure 31: Rotax 912 UL/ULS/iS cooling system with thermostat



# MAINTENANCE MANUAL SAVANNAH S

Doc. No.:	MM-SVNH-EN
Revision:	07
Rev. Date:	07/11/2022
Proj. Ref.:	SVNH S

## 6.7. Brake system

Follows the layout of the braking system.

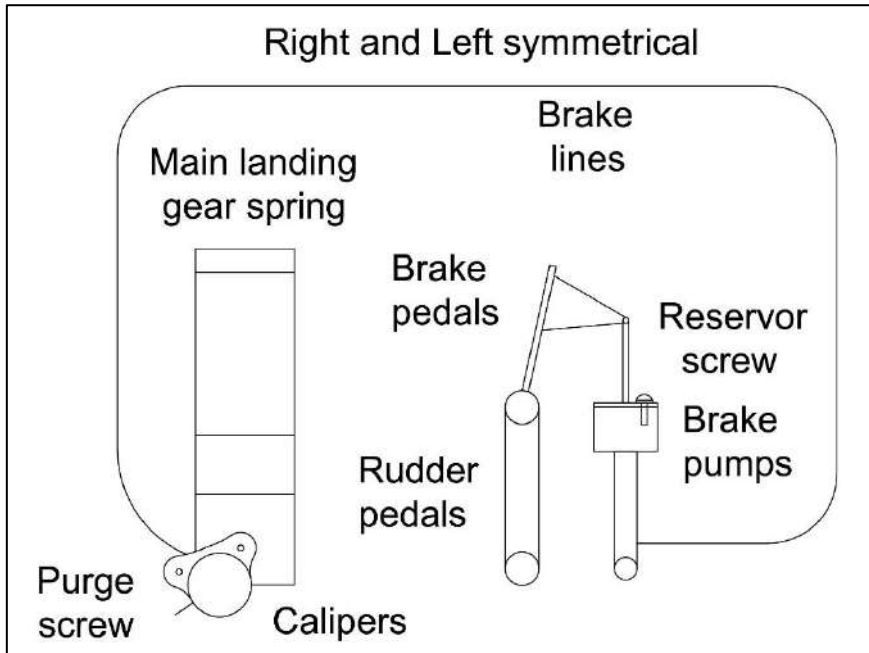

Figure 32: Standard brake system (only right side is shown, the left is identical, symmetrical)

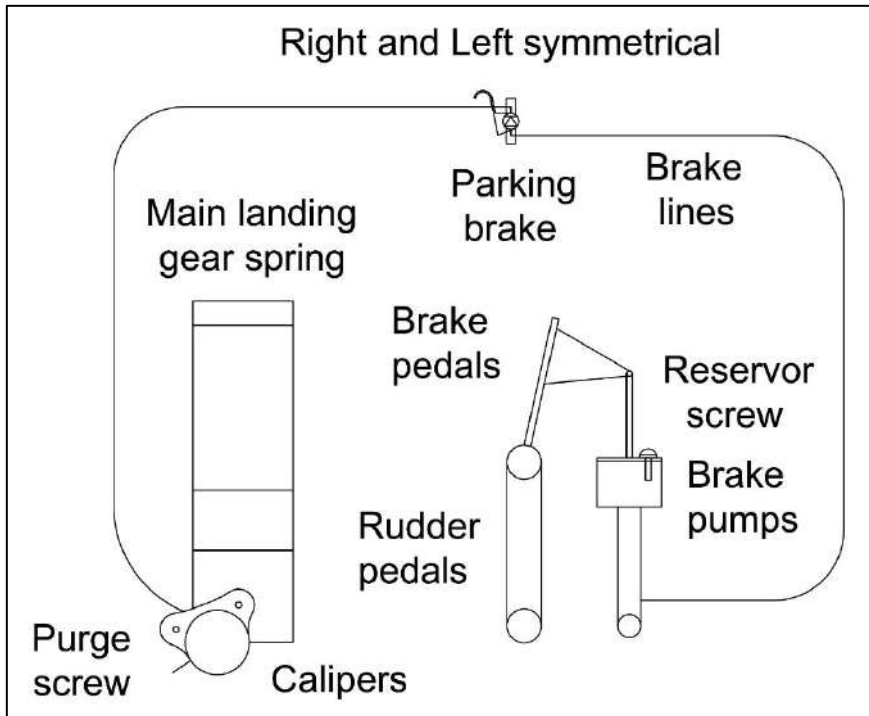

Figure 33: Brake system with parking brake (only right side is shown, the left is identical, symmetrical)



# MAINTENANCE MANUAL SAVANNAH S

Doc. No.: MM-SVNH-EN

Revision: 07

Rev. Date: 07/11/2022

Proj. Ref.: SVNH S

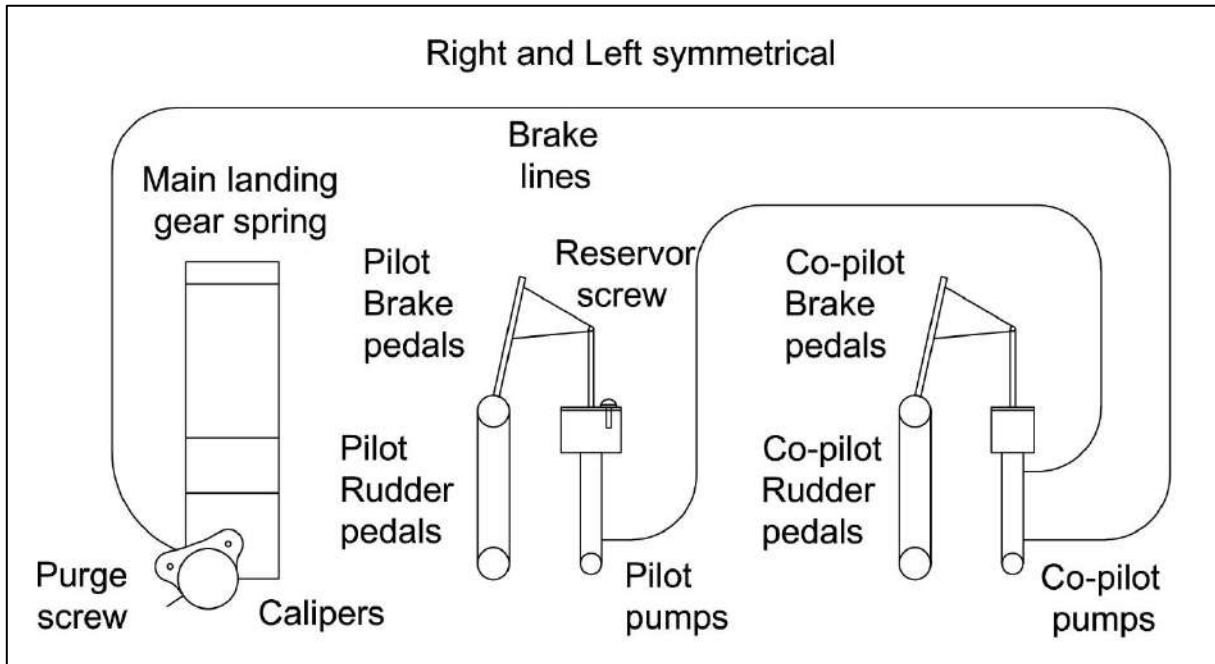

Figure 34: Double side brake system (only right side is shown, the left is identical, symmetrical)

## 6.8. Cabin heating and ventilation

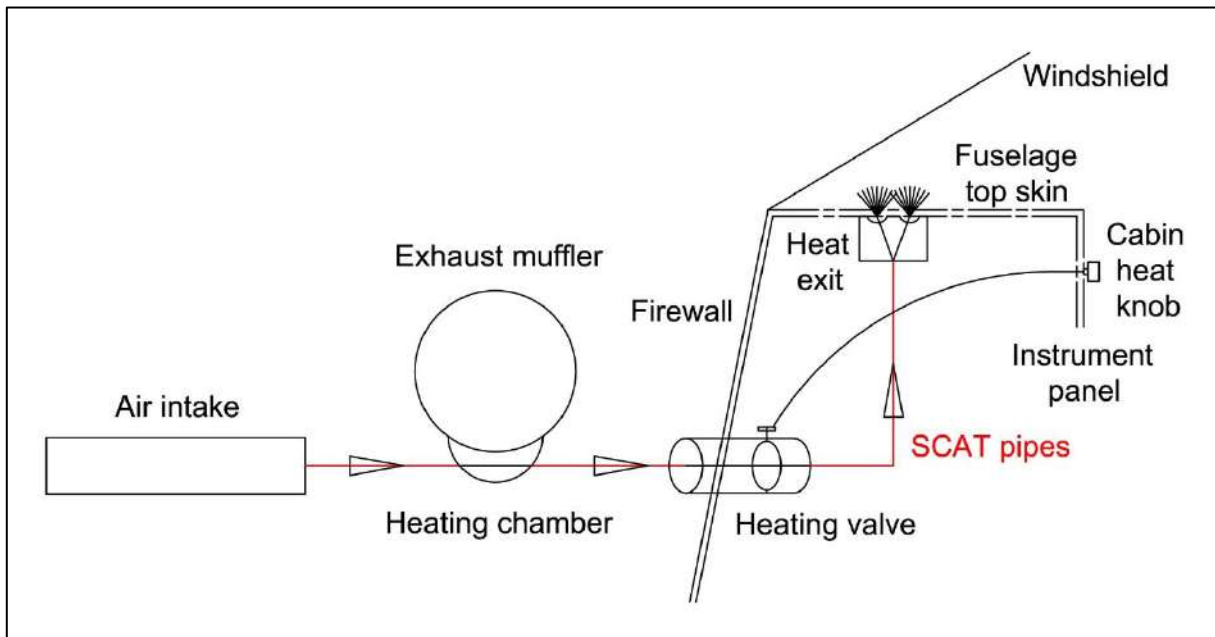

Figure 35: Cabin heating system

The ventilation of the cabin is assured by two round ports called snap-vent, installed on the side window of the door, one per each.



# MAINTENANCE MANUAL SAVANNAH S

Doc. No.:	MM-SVNH-EN
Revision:	07
Rev. Date:	07/11/2022
Proj. Ref.:	SVNH S

## 6.9. Electrical system

The power supply during continuous operation is assured by a Rotax engine internal AC generator with rectifier which assures 250 [W] at 14.2 +/-0.3 [V] DC nominal, with maximum 22 [A] current.

The engine start and the non-continuous operations without generator active (min. 30 minutes), are assured by the aircraft battery which can be selected between the followings:

Battery	Model	Nominal Voltage	Energy [Ah]
UNIBAT sealed lead-acid VRLA (standard)	CBTX20CH-BS	12.6	18
UNIBAT sealed lead-acid VRLA (light)	CTZ10S-BS	12.6	8.6
UNIBAT lithium LiFePo4 (light)	ULT3	12.8	5

Table 29: Battery type

Follows the electrical wiring of the aircraft.

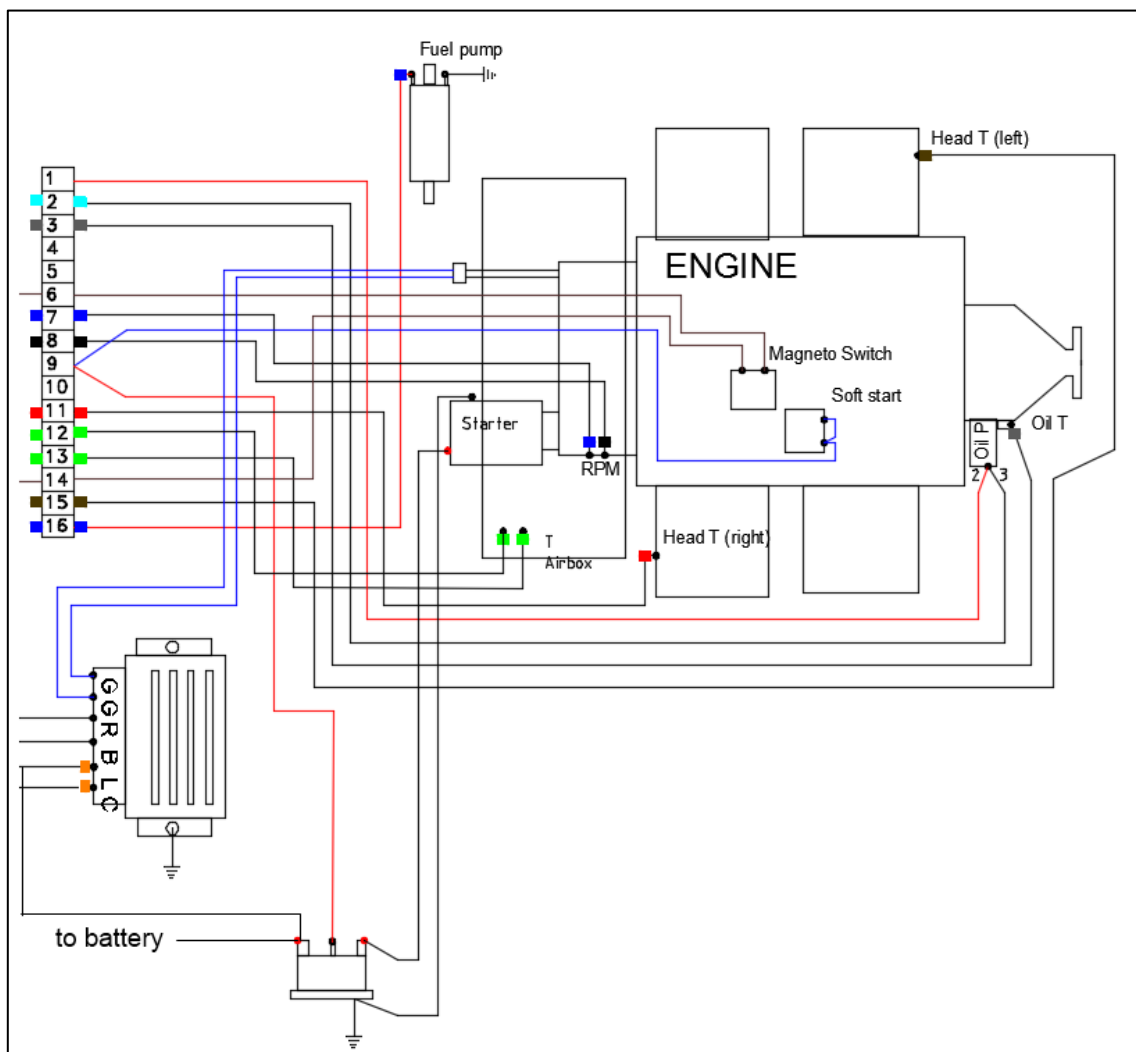

Figure 36: Electrical wiring of engine compartment



# MAINTENANCE MANUAL SAVANNAH S

Doc. No.: MM-SVNH-EN

Revision: 07

Rev. Date: 07/11/2022

Proj. Ref.: SVNH S

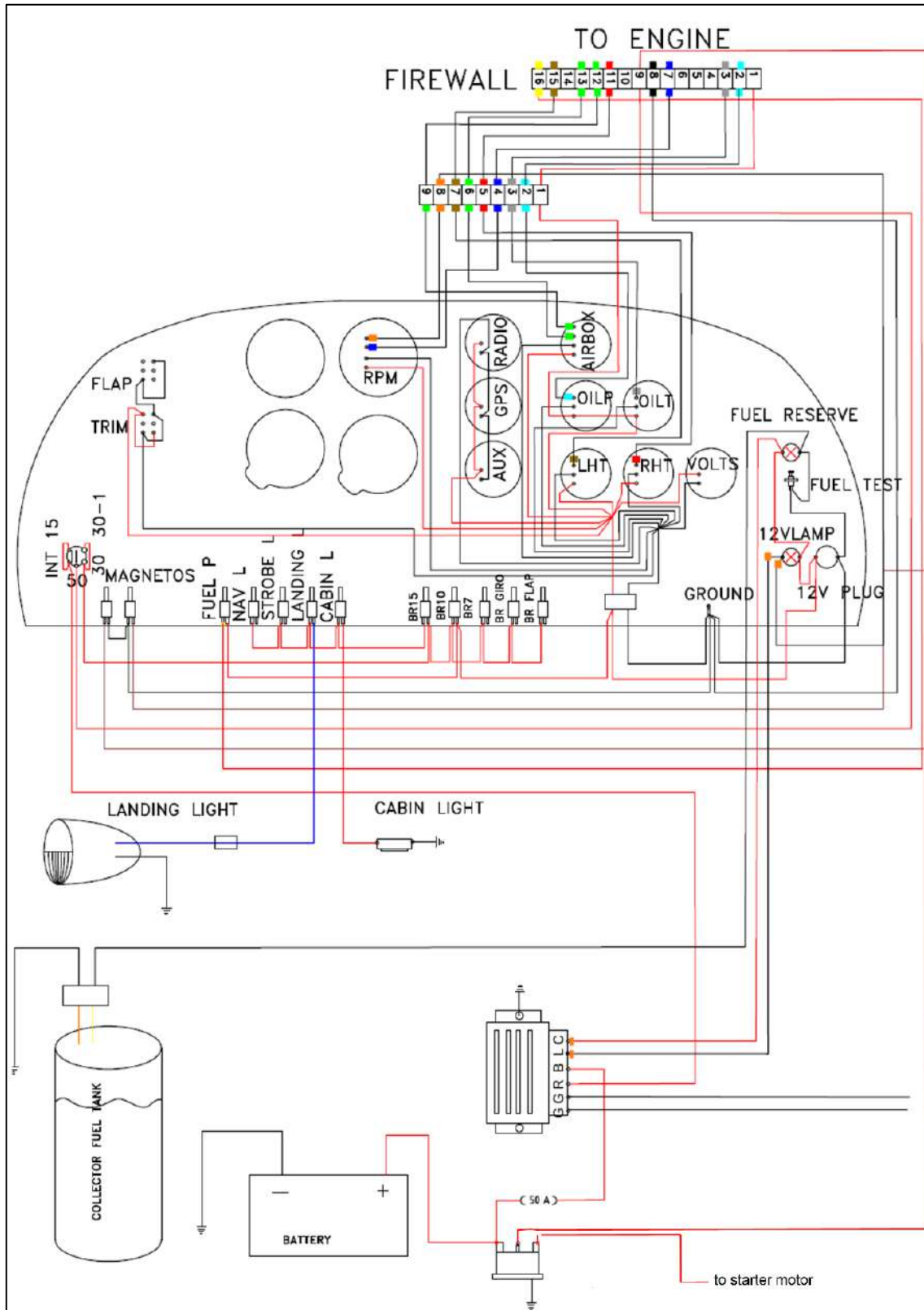

Figure 37: Electrical wiring firewall backward



	<b>MAINTENANCE MANUAL SAVANNAH S</b>	<b>Doc. No.:</b> MM-SVNH-EN
		<b>Revision:</b> 07
		<b>Rev. Date:</b> 07/11/2022
		<b>Proj. Ref.:</b> SVNH S

## 6.10. Configuration, equipment, instruments and avionics

<b>Minimum Equipment List (excluded engines and propellers)</b>	
Fuel system	Auxiliary Electric Fuel Pump - Facet
Powerplant Systems	ICP Exhaust
	Throttle lever
	Intake carburettor filters
Seats	4 points Seat Harnesses - ICP
Wheel	Wheel and Tyres (any)
	Brakes system - ICP
Flight Instruments	Compass - ICP 80 [mm]
	Airspeed Indicator [km/h] - ICP 80 [mm]
	Altimeter [ft] - ICP 80 [mm]
Engine Instruments	RPM & Hourmeter Indicator - VDO ICP
	Oil Pressure - Luciano Sorlini
	H2O Temperature Rx or Lx - VDO
Manuals	Flight Manual (POH)

*Table 30: Minimum Equipment List*



# MAINTENANCE MANUAL SAVANNAH S

**Doc. No.:** MM-SVNH-EN

**Revision:** 07

**Rev. Date:** 07/11/2022

**Proj. Ref.:** SVNH S

### Standard Configuration and Equipment for Ready To Fly aircraft (excluded engines and propellers)

Powerplant Systems	ICP Exhaust
	Double throttle lever
	Choke knob
	Intake carburettor filters
Propeller accessories	ICP Spinner $\phi$ 260 [mm]
	ICP Aluminium Spacer for DUC Swirl and Ivoprop Patriot
Fuel system	Auxiliary Electric Fuel Pump - Facet
Rescue System	Junkers Magnum 501
Seats	Black Fabric seats cover
	4 points Seat Harnesses - ICP
Wheel	6" Tyres - ICP
	Brakes system - ICP
Trim	Electric Trim + Switch + Indicator
Flight Instruments	Compass - ICP 80 [mm]
	Airspeed Indicator [km/h] - ICP 80 [mm]
	Altimeter [ft] - ICP 80 [mm]
	Vertical Speed Indicator [ft/min] - ICP 80 [mm]
	Round Slip Indicator - ICP 57 [mm]
Engine Instruments	RPM & Hourmeter Indicator - VDO ICP
	Oil Pressure - Luciano Sorlini
	Oil Temperature - Motometer
	H2O Temperature Rx - VDO
	H2O Temperature Lx - VDO
	Fuel Pressure - Strumentazione Industriale
	Voltmeter - VDO
Airbox & External Temperature Indicator - ICP	
Other	12V Plug
Lights	Landing light - ICP
	Cabin light - ICP
Painting	White ICP + ICP Logo decal
Cabin Vent	Doors Snap Vent
Manuals	Flight Manual (POH)
	Maintenance Manual (MM)
	Spare Part Catalogue

*Table 31: Standard configuration*



# MAINTENANCE MANUAL SAVANNAH S

<b>Doc. No.:</b>	MM-SVNH-EN
<b>Revision:</b>	07
<b>Rev. Date:</b>	07/11/2022
<b>Proj. Ref.:</b>	SVNH S

Optional Configuration, Avionics and Equipment (excluded engines and propellers)	
Powerplant Systems	ICP Airbox with Filter and temperature probe
	Carburettor heating
	Carburetors drip tray
	Oil thermostat
	Water thermostat
Propeller Spacer	ICP Aluminium Spacer for DUC Flash
Spinner	DUC Carbon spinner $\phi$ 250 [mm]
Rescue System	Junkers Magnum 601
Baggage area	Baggage hooks and retaining latches
	Big luggage area (parachute not installable)
Wheel	4" Tyres - ICP
	8" Tundra Tyres - ICP
	Speciality Tires of America, Inc. - Air Trac 16x6x6.00 AA1E4
	Speciality Tires of America, Inc. - Aero Trainer 16x6x6.00 AD4E4
Landing gear	Tail Dragger
Tail wheel	6" tail wheel MATCO
	8" Tail wheel MATCO (standard)
Wheel Fairing	4" Wheels Fairing
	6" Wheels Fairing
Flap	Electrical actuation + Panel Switch + Position Indicator
Control Stick	Double Control Stick
	Ray Allen Stick Grip Left + Trim Control Button+ PTT
	Ray Allen Stick Grip Right + PTT
Fuel System	140 [lt] Double Wing Fuel Tank
	18 [lt] Collector Tank + Indicator Unit
	Shut-off valve for left Wing only
Brake System	Right side Brake Pedals
	Parking Brake System
	Double Brake calipers (for Tail Dragger only)
Cabin Heating	Cabin Heating & Defrost System
Other	USB Plug
Air Towing	Towing System - ICP
Lights	Wheelen Stobo&Nav Wing lights
	Wheelen Stobo&Nav Tail light
	Thiesen Electronics EPTA-NG Stobo&Nav wing lights
	Thiesen Electronics TL-NG Stobo&Nav tail light

*Table 32a*



# MAINTENANCE MANUAL SAVANNAH S

<b>Doc. No.:</b>	MM-SVNH-EN
<b>Revision:</b>	07
<b>Rev. Date:</b>	07/11/2022
<b>Proj. Ref.:</b>	SVNH S

Optional Configuration, Avionics and Equipment (excluded engines and propellers)	
Seats	Leather seats
	Forwarded position of rudder pedals
	Adjustable position seats
	Wedge spacer for seats
Door	Door Front Lock
	Door Rear Lock
	Door arm rest
	Square sliding window (for photo)
Vent	Fuselage Side Vent
Furnishing	Sun visor
	Central Control Stick cover
	Central Control Stick leather cover
	Control Stick Leather cover for dual control stick
	Document drawer (rudder cables cover)
	Cabin upholstery
	Courtesy mats
Accessories	Tie-down kit
	Lifting Hook
	Towing Bar
Painting	Cabin Cover
	Integral Parts Primer
	Custom colors and design
	Arrow Cowling & Tail decals
Manuals for Kit	Custom decals
	Construction Manual
	Technical Specification SXXXX
Flight Instruments & Navigation	Airspeed Indicator Winter 57 [mm]
	Altimeter Winter 57 [mm]
	Vertical Speed Indicator Winter 57 [mm]
	Winter Slip Indicator
	Turn and Bank Indicator - ICP
	Garmin AERA gps system (500, 660, 760)
	Garmin G5 system (monitor + modules)
	Garmin G3X system (monitor + modules)

*Table 32b*



# MAINTENANCE MANUAL SAVANNAH S

<b>Doc. No.:</b>	MM-SVNH-EN
<b>Revision:</b>	07
<b>Rev. Date:</b>	07/11/2022
<b>Proj. Ref.:</b>	SVNH S

Optional Configuration, Avionics and Equipment (excluded engines and propellers)	
Flight Instruments & Navigation	Dynon EFIS-D10A (monitor + modules)
	Dynon SV-D700 (monitor + modules)
	Dynon SV-D1000 (monitor + modules)
	Dynon SV-HDX1100 7"/10" (monitor + modules)
	MGL iEFIS Discovery 7"
	MGL iEFIS Explorer 8.5"
	AVMap UltraEFIS
	Kanardia INDU (ASI, Alt, VSI, RPM) 57/80 [mm]
	Kanardia HORIS (ATT) 57/80 [mm]
	Kanardia NESIS (EFIS+EIS) 7"/10"
	TruTrac ADI
	TruTrac GP EFIS
	ELT ACK E-04
	ELT - Artex 345
Engine Instruments	Manifold Pressure - ICP
	Flybox Vigilus
	Garmin G3X system (monitor + modules)
	Dynon EMS-D10 (monitor + modules)
	Dynon SV-D700 (monitor + modules)
	Dynon SV-D1000 (monitor + modules)
	Dynon SV-HDX1100 7"/10" (monitor + modules)
	MGL iEFIS Discovery 7"
	MGL iEFIS Explorer 8.5"
	AVMap EngiBOX
	Kanardia NESIS (EFIS+EIS) 7"/10"
Kanardia EMSIS (EIS)	
UMA 2 1/4 in mechanical manifold pressure gauge	
Other instruments provision	Airgizmos Rack AERA 660
	Airgizmos Rack AERA 760
	Airgizmos Rack iPad 10"
	Airgizmos Rack iPad Mini
	Garmin Auto Pilot system and servo
	Dynon Auto Pilot system and servo
TruTrac Digiflyte Auto Pilot and servo	

*Table 32c*



# MAINTENANCE MANUAL SAVANNAH S

<b>Doc. No.:</b>	MM-SVNH-EN
<b>Revision:</b>	07
<b>Rev. Date:</b>	07/11/2022
<b>Proj. Ref.:</b>	SVNH S

Optional Configuration, Avionics and Equipment (excluded engines and propellers)	
Radio	Panel Push-To-Talk Button
	Headset plugs on Instrument Panel lower bar
	Headset plugs on Baggage compartment
	COM - Funke ATR833-II
	TRX - Funke TRT800H
	COM - TQ KRT2
	TRX - TQ KTX2
	COM - Trig TY91/TY92
	TRX - Trig TT21/TT22
	ELT - ACK E-04
	ELT - Artex ELT345
	ELT - Kannad 406
	COM - Dynon SV-COM-X83
	TRX - Dynon SV-XPNDR-26X
	COM - Garmin GTR200/200B
	TRX - Garmin GTX335
	COM - X-Com VHF Radio and Comant 121 Antenna
	TRX - Microair T2000 Mode S or Mode C Transponder
	Intercom - Dynon SV-INTERCOM-2S
	Intercom - Flightcom 403
Intercom - PS Engineering PM 500/1000/3000	
Intercom -Garmin GMA 240/340	
Intercom - Universal radio interface AA34-300	
FLARM V3	
Flarm Garrecht Air Traffic AT-1	
Headset	Clearcom (2x)

*Table 32d (a-d): Optional configuration, avionics and equipment*

### NOTE

Additional equipment can be installed accordingly to a formal approval of the aircraft manufacturer I.C.P. Srl; contacts [info@icp.it](mailto:info@icp.it)

	<b>MAINTENANCE MANUAL SAVANNAH S</b>	<b>Doc. No.:</b> MM-SVNH-EN
		<b>Revision:</b> 07
		<b>Rev. Date:</b> 07/11/2022
		<b>Proj. Ref.:</b> SVNH S

## 6.11. Painting

Following materials are used for the aircraft external protection.

Area	Description	Product
Assembly interface	Parts interface primer	Primer for Aluminium, Varnish water based matt paint RV-99
Cleaning	Aluminium parts cleaning and prepares for painting (degreaser)	PPG Solvent Cleaner High Efficacy D845
	Primerized parts cleaning and prepares for painting (degreaser)	Lechler Hydro Cleaner Slow 00665
External paint	External water based paint	Lechler Hydrocryl 2K + pigments + hardener 50% + water 15%
Primer (optional)	Parts integral primer water based	Lechler Hydropur Primer + hardener 15% + water 25%

Table 33: Painting products

### NOTE

Different type of painting or product (or mix to obtain RAL colors) can be used to protect the airplane or protect parts during not scheduled interventions or repairs. In that case, I.C.P. Srl can not assure the same protection level against corrosion in respect of the indicated products and procedures for painting, combined to best personnel practices. The standard procedures for painting are shown in the product datasheet, available in the producer website



# MAINTENANCE MANUAL SAVANNAH S

Doc. No.:	MM-SVNH-EN
Revision:	07
Rev. Date:	07/11/2022
Proj. Ref.:	SVNH S

**Left intentionally blank**



	<b>MAINTENANCE MANUAL SAVANNAH S</b>	<b>Doc. No.:</b> MM-SVNH-EN
		<b>Revision:</b> 07
		<b>Rev. Date:</b> 07/11/2022
		<b>Proj. Ref.:</b> SVNH S

## 7. Maintenance descriptions

### 7.1. Control surface travel setting

The following chapters describe how to set the control surfaces neutral position and travel.

#### 7.1.1. Flaperon as aileron

All the push-pull rod of the lateral control are fixed in length and is not necessary to operate adjustments. The only section to modify to operate the neutral setting of the Flaperon is constituted by the first vertical push-pull rods after the torque tube bell crank. The following sequence permits to align both flaperons at zero angle of deflection:

- Set control stick in the center (90° in respect of the cabin floor) and lock it. Alternatively (less precision), set the torque tube bell crank horizontally;
- Set the Flap UP. In case of electric Flap actuator, switch on the Master, set Flap 1/2 and then set the Flap fully UP newly. The voltage of the battery must be about 12.5 [V], the engine must be off;
- Set the left inner Flaperon on the ZERO of the jig SA200VG. The tolerance during the ground setting is +/-0.5°;
- Set the right inner Flaperon on the ZERO of jig SA200VG,
- Verify the setting with the following procedure:
- Unlock the control stick and move it;
- Move the left inner Flaperon by hand and set to the ZERO of the jig SA200VG;
- Not touch any part of the aircraft;
- Check the right inner Flaperon resultant angle, it must be ZERO on the jig SA200VG;
- If different values are found, correct as follows,
- If right inner Flaperon results higher, rotate closing the first right push-pull rod uniball of approximately 2 turn to obtain 0.5° Flaperon angle of variation;
- Attention: the Flaperon can not be set with a difference higher that 0.5°, alternatively the control stick can not have an angle more than 1° in respect of the vertical alignment;
- Attention: rotating the uniball of push-pull rod, do not set excessively unsymmetrical the upper in respect of the lower one. The minimum uniball insertion allowed in the rod is 5 pitches of thread;
- Attention: the uniball must be locked with counter-nut, closing against the rod at approximately 6 [Nm].



# MAINTENANCE MANUAL SAVANNAH S

Doc. No.: MM-SVNH-EN

Revision: 07

Rev. Date: 07/11/2022

Proj. Ref.: SVNH S



Figure 38: Flaperon jig SA200VG and position on the first wing rib



Figure 39: Position of jig SA200VG near the first rib rivets line, aligned to wing trailing edge



# MAINTENANCE MANUAL SAVANNAH S

Doc. No.: MM-SVNH-EN

Revision: 07

Rev. Date: 07/11/2022

Proj. Ref.: SVNH S

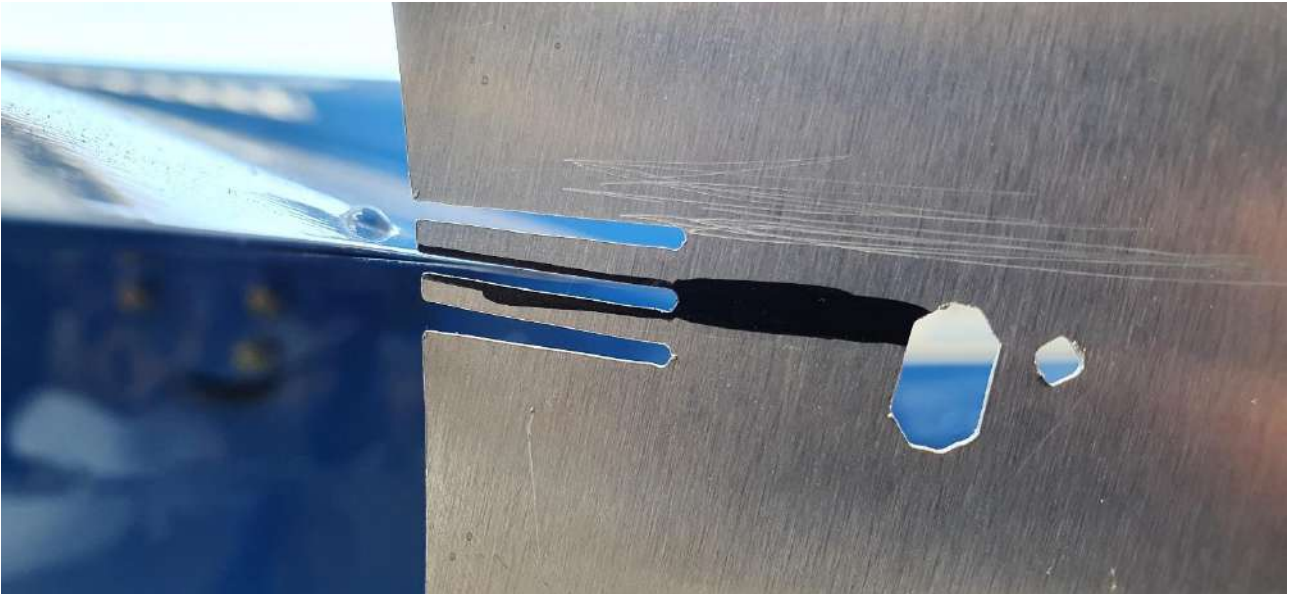

Figure 40: ZERO setting of the left inner Flaperon. Marks of +/- 0.5° of tolerance

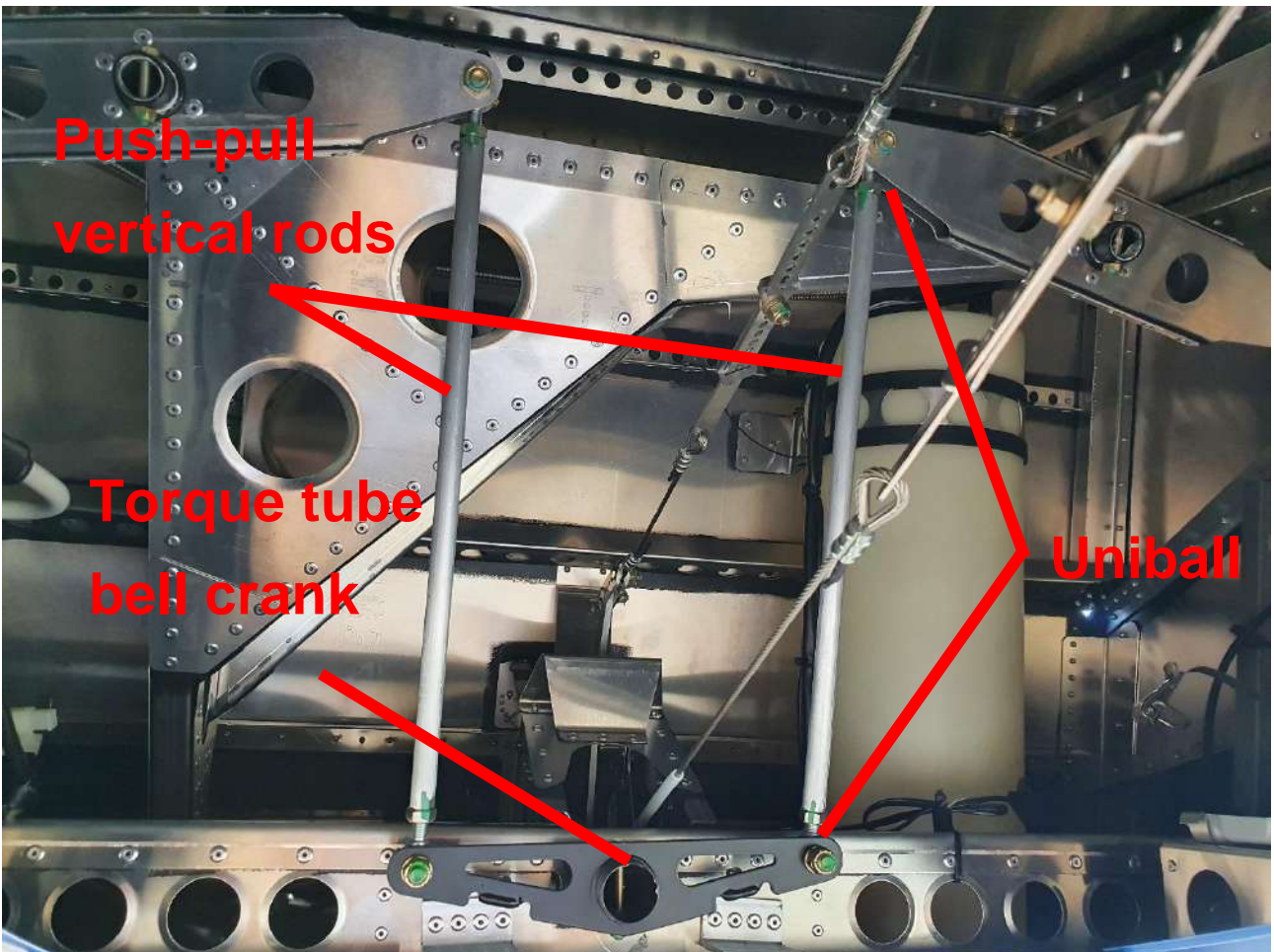

Figure 41: Push-pull rods for Flaperon setup

	<b>MAINTENANCE MANUAL SAVANNAH S</b>	<b>Doc. No.:</b> MM-SVNH-EN
		<b>Revision:</b> 07
		<b>Rev. Date:</b> 07/11/2022
		<b>Proj. Ref.:</b> SVNH S

The following *Table 34* reports the design dimensions of the push-pull rod of the lateral control system, from uniball to uniball center (codes on CM and SPC of reference documents in *Chapter 1.2*):

Code	Length [mm]
SC203	375 +/-2 plus eventual setting
ST124	470 +/-2

*Table 34: Lateral CS push-pull rods dimensions*

### 7.1.2. Flap indications

Applicable chapter only for the electric flap actuation. The indication for mechanical actuation is made by direct feeling.

Considering the ZERO setting of the flaperons described in *Chapter 7.1.1*, the Flap indicator must be in the fully up position, fist upper green LED active only. To regulate this indication, perform the following procedure:

- Open the left lower seat inspection panel by removing the four corner rivets (this operation usually is done only for the first setting or actuator replacement);
- Unscrew the electric potentiometer bracket installed parallel to the actuator rod;
- Move the electric potentiometer in the proper position by monitoring the Flap indicator (Master must be active);
- Verify that for Full Flap the indicator goes down to the last lower LED indication;
- Close the two screw of the electric potentiometer bracket;
- Close the seat inspection panel with rivets.

### 7.1.3. Flight check of Flaperons

During flight at approximately 500 [kg] of weight, two occupants of same weight on-board (side CG centered if differently obtainable), leveled cruise condition at 75% of power (5000 [RPM]), no turbulence, no wind and below 2500 [ft] of Density Altitude, the aircraft must flight straight and stable with the control stick centered. If the control stick is not centered, execute entirely the procedure of the *Chapter 7.1.1*. If the airplane roll on the left, land and bent lightly the trailing edge of the entire outer Flaperon without creating damage or visible bent line: bent up the left Flaperon and bent down the right Flaperon. Bent in the opposite relative directions if the airplane rolls to the right. Verify the behavior in a second flight and repeat if necessary.

### 7.1.4. Elevator control system

The longitudinal flight control surface is set by means of the cables passing in the fuselage cone, accessible from the lower trap door. The following procedure must be applied:



## MAINTENANCE MANUAL SAVANNAH S

Doc. No.:	MM-SVNH-EN
Revision:	07
Rev. Date:	07/11/2022
Proj. Ref.:	SVNH S

- The elevator cables must be pulled at proper tension by means of Nonio tender (see *Chapter 1.14.7*), with a preliminary length setting;
- Zeroing a digital level bubble (with  $0.1^\circ$  of resolution) in the upper skin of the Stabilizer in the position shown in *Figure 42*;
- Pull the control stick totally backward (full nose up). The position must be limited only by the line stop which is the bell crack support, shown in *Figure 43*. The position of the stick is directly fixed because the length of the push-pull rod is not to be modified in respect of design values (*Table 35*);
- Check the Elevator deflection with the digital level in the position shown in *Figure 44*. The angle read must be  $19^\circ$  with  $\pm 0.5^\circ$  of tolerance *Figure 45*. Attention: the Elevator deflection angle in respect of its chord is rotated of  $+6^\circ$  because the reading of the bubble is performed in the upper skin of the Elevator;
- If the angle resultant is not correct, perform the following procedure:
- Change the Elevator cables length changing both the nonio tenders, the upper and the lower, with the same offset of holes: one enlarging and the other one shortening;
- Verify newly the Elevator maximum deflection angle and repeat the operations to obtain the correct value;
- When values are correct, check again the cables tension with the tensiometer, at 18-24 [lbs]. If different, change the tension adjusting symmetrically the Nonio tender.

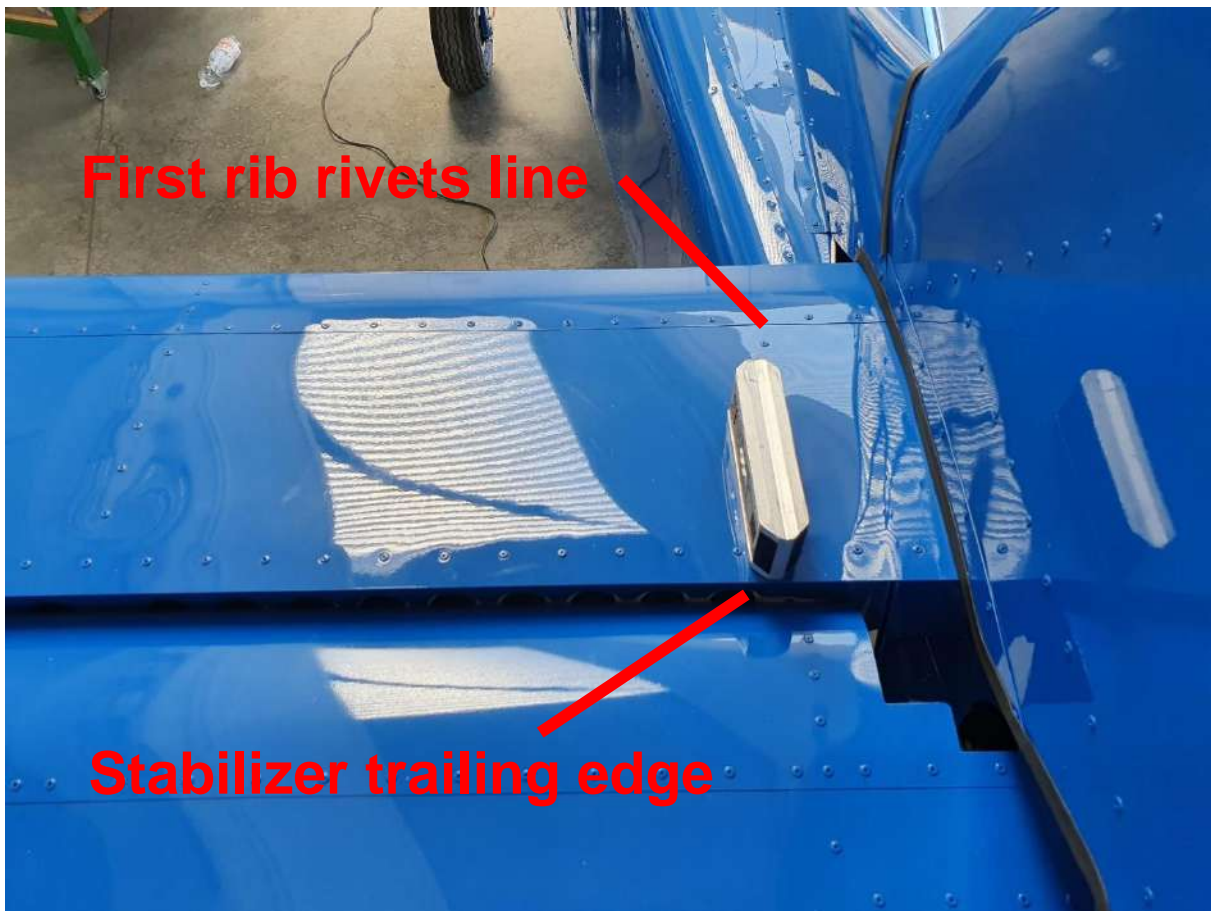

Figure 42: Digital spirit level position on Stabilizer for Zeroing



# MAINTENANCE MANUAL SAVANNAH S

Doc. No.: MM-SVNH-EN

Revision: 07

Rev. Date: 07/11/2022

Proj. Ref.: SVNH S



Figure 43: Longitudinal line bell crank on the full nose up position, against stop



Figure 44: Digital spirit level position on Elevator

	<b>MAINTENANCE MANUAL SAVANNAH S</b>	Doc. No.: MM-SVNH-EN
		Revision: 07
		Rev. Date: 07/11/2022
		Proj. Ref.: SVNH S



Figure 45: Elevator final setup deflection angle

The following *Table 35* reports the design dimensions of the push-pull rod of the longitudinal control system, from uniball to uniball center (codes on CM and SPC of reference documents in *Chapter 1.2*):

Code	Length [mm]
SS035	530 +/-0.5

Table 35: Longitudinal CS push-pull rod dimension

### 7.1.5. Rudder control system

#### 7.1.5.1. Rudder pedals alignment to rudder and nose wheel

Basically the Rudder, the nose wheel and the Rudders pedals must be aligned together and straight. To obtain this setting, follows the sequent procedure:

	<h1 style="margin: 0;">MAINTENANCE MANUAL</h1> <h1 style="margin: 0;">SAVANNAH S</h1>	Doc. No.: MM-SVNH-EN
		Revision: 07
		Rev. Date: 07/11/2022
		Proj. Ref.: SVNH S

- Verify the installation of the push-pull rod of the steering, going to the front landing gear. The length of the rods should not modified from design dimensions;
- The nose wheel must be longitudinally aligned when the rudder pedals are straight;
- If the Rudder pedals (left pilot side is the reference) are not aligned when the wheel is longitudinally straight, move the pedals to obtain the alignment. Then adjust properly the push-pull rods uniball to obtain the nose wheel straight consequently. The uniball adjustment must be always done by closing the uniball (shortening the rod in respect of design values);
- With the Rudder pedals always aligned together, pull the cables at the proper tension by means of Nonio tender (11-15 [lbs]);
- Check the Rudder surface is aligned longitudinally straight to the Fuselage;
- If the Rudder is not longitudinally aligned, modify the cables length by regulating the Nonio tender with same number of holes, unsymmetrically (the one adding and the other one subtracting holes);
- Verify the Rudder alignment and when found correct check again the cable are tensioned as prescribed.

#### 7.1.5.2. Rudder ground adjustable (flettner) tab deflection

The ground adjustable tab installed on the Rudder surface is necessary to obtain a directional alignment (sideslip ball centered) of the airplane during leveled cruise flight at 75% of power (5000 [RPM]), no turbulence, no wind, below 2500 [ft] of Density Altitude and approximately 500 [kg] of weight with two occupants of same weight on-board (side CG centered if differently obtainable). During this flight condition, set the roll at zero Bank angle eventually maintained by piloting with control stick and then free the Rudder pedals control; weight the condition is stable an observe if the airplane goes directionally on the left or right, therefore the sideslip ball is on the left or right respectively. In case of left, land the airplane and set the ground adjustable tab bent lightly on the left. Then flight again and observe consequently the behavior and correct newly if required. The following *Table 36* reports the design dimension of the push-pull rods of the directional control system, from uniball to uniball center (codes on CM and SPC of reference documents in *Chapter 1.2*):

Code	Length [mm]
SL075 (left)	313 +/-2
SL076 (right)	335 +/-2

*Table 36: Directional CS (steering) push-pull rods dimension*

#### 7.1.6. Elevator Trim Tab setup

The elevator trim tab setup is verifiable only in-flight; the initial setup is done with the design dimension of the push-pull rods of the trim tab actuator, reported in *Table 37*. With the airplane in flight at leveled condition with full power, no turbulence, no wind, below 2500 [ft] of Density Altitude, approximately 500 [kg] of weight (two occupants) and 5 kg in the baggage compartment, the trim tab should maintain the aircraft trimmed leveled at the full nose down trim position and coherent indication. If the aircraft rise the nose up with controls free, in that speed and trim full down conditions,



	<b>MAINTENANCE MANUAL SAVANNAH S</b>	<b>Doc. No.:</b> MM-SVNH-EN
		<b>Revision:</b> 07
		<b>Rev. Date:</b> 07/11/2022
		<b>Proj. Ref.:</b> SVNH S

the Elevator trim tab must be rotated up; if the aircraft goes down, the tab must rotated down. To rotate the trim tab upward, unscrew the uniball of the push-pull rod near the tab; attention to maintain the uniball almost symmetrical in the rod and always verify the counter nut closure (M5 at approximately 3 [Nm]). Attention when unscrewing, the minimum uniball insertion allowed in the rod is 5 pitches of thread. If the behavior is opposite, of course rotate opposite the push-pull rod. If not sufficient the intervention on the push-pull rod connected directly to the trim tab, is possible also to work on the push-pull rod connected to the trim actuator. In this case, the logics of intervention when screwing or unscrewing the uniball is the opposite.

Code	Length [mm]
SG023 (to trim tab)	295 +/-2
SG024 (to actuator)	211 +/-2

Table 37: Trim tab push-pull rods dimension

### 7.1.7. Tail wheel landing gear (if configured with)

The tail wheel should aligned with the Rudder and is possible to regulate that position by means of the steering control cables. This cables are fixed in length, but one ends has an adjustment plate with many holes, to tension or release the cable, in function of the direction of rotation needed.

### 7.1.8. Brake pedals position on Rudder pedals

To orient the brake pedals is only necessary to regulate the length of the brake pumps. When enlarged the end fitting of the pump rod, the pedals goes back near to the pilot; when shortening the length, the pedals rotate forward. Attention to set the brake pedals symmetrically, with the Rudder pedals also aligned. Attention; do not unscrew too much the end fitting of the pump rod because of strength capacity, minimum insertion allowed is 5 pitches of thread.

Another method to orient the brake pedals differently is to modify the position of the Rudder pedals, setting them more forward or backward by enlarging or shortening respectively the steering push-pull rods. Consequently, it is necessary to regulate the Rudder cables and verify that the tension is set correctly. Refer to the dedicated procedures of *Chapter 7.1.5*. Is not suggested this option; attention to not change excessively the positions of pedals because the pumps reservoir (larger section) can touch the brake pedals at the end of Rudder travel.

## 7.2. Control surface free play with controls locked

General verification if the line is properly strength and inelastic. Small pressure on surface trailing edge with control system locked, must results in a maximum of couple of millimeters of free surface deflection (measured at trailing edge).



# MAINTENANCE MANUAL SAVANNAH S

Doc. No.:	MM-SVNH-EN
Revision:	07
Rev. Date:	07/11/2022
Proj. Ref.:	SVNH S

## 7.3. Control surfaces hinges

All the control surfaces hinges are made with the sequence of parts as shown below in *Figure 46*. The bushing is the part number SC21X, where X indicates different length (i.e. 0, 2, 7). To set correctly the closure of the hinge, close the castle nut up to touching all the surfaces and then install the cotter pin, without forcing. If the hinge point take excessive free play, not more than 0.5 [mm] evaluated manually and visually, remove the cotter pin and close 1 tooth additionally the castle nut, then re-install the cotter pin. Attention: do not close excessively the nut because it can force the hinge point around the rotation. After the setup, check the hinge point free play within tolerance and verify the cotter pin is installed rigidly.

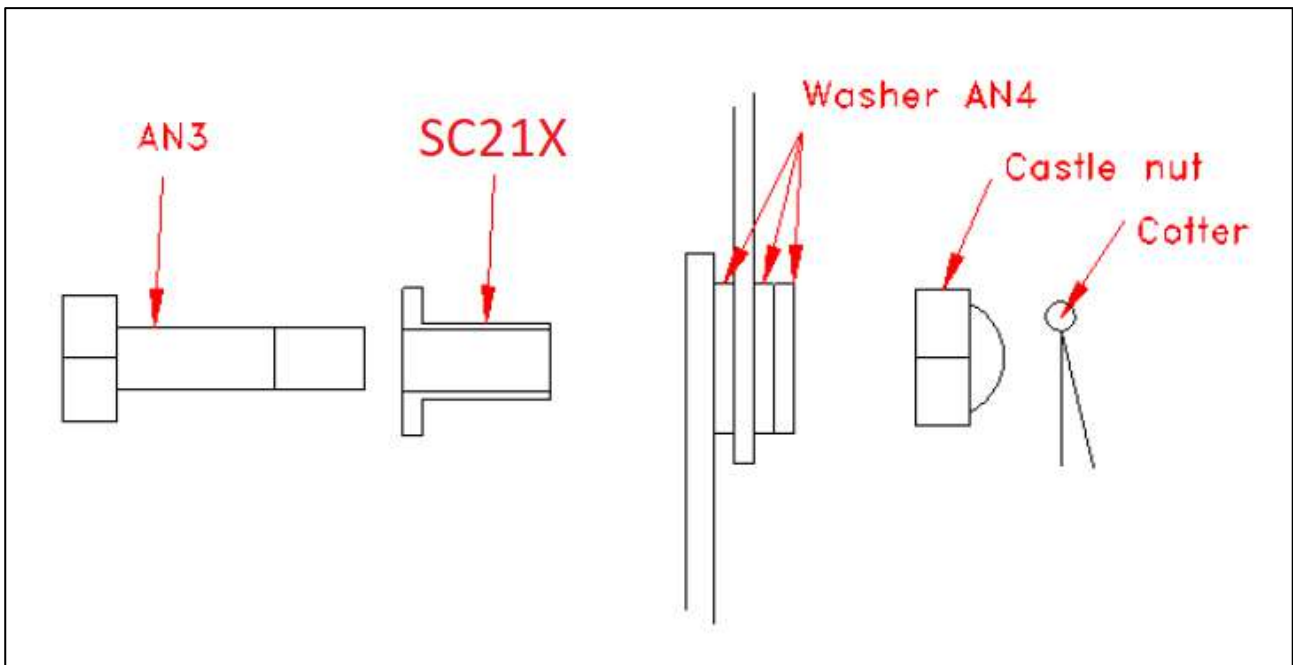

Figure 46: Control surfaces hinges

## 7.4. Fuel system drainage

To drain the fuel system basically open the fuel drain valve located below to the Collector tank. If the airplane is in levelled reference on-ground attitude, a couple of litres could remain in the system; for a complete draining, incline the airplane with tail down, wait few minutes and then drain entirely from draining valve. To remove the unusable fuel, open the delivery hose of the electric fuel pump and then drain from that.

## 7.5. Brakes system bleeding

The brakes oil system can be drained from the lower screw of the brakes caliper. The right brake and left brake systems are independent, therefore both side must be drained.

	<b>MAINTENANCE MANUAL SAVANNAH S</b>	Doc. No.: MM-SVNH-EN
		Revision: 07
		Rev. Date: 07/11/2022
		Proj. Ref.: SVNH S

To bleed the system, remove totally the oil or part of it, then add the new oil from the lower draining screw and monitor the level rising in the pump tank (its larger section). The oil level need not to be higher than half of pump tank area, which is approximately 20 [mm] from the top corner of the pump (ref. *Figure 47*).

The level can be monitored by removing the screw of the cup on top of brake pump; then install again the screw.

After bleeding, verify that in the lines there is no presence of bubbles major than 15 [mm] of length. If major, bleed again the system.

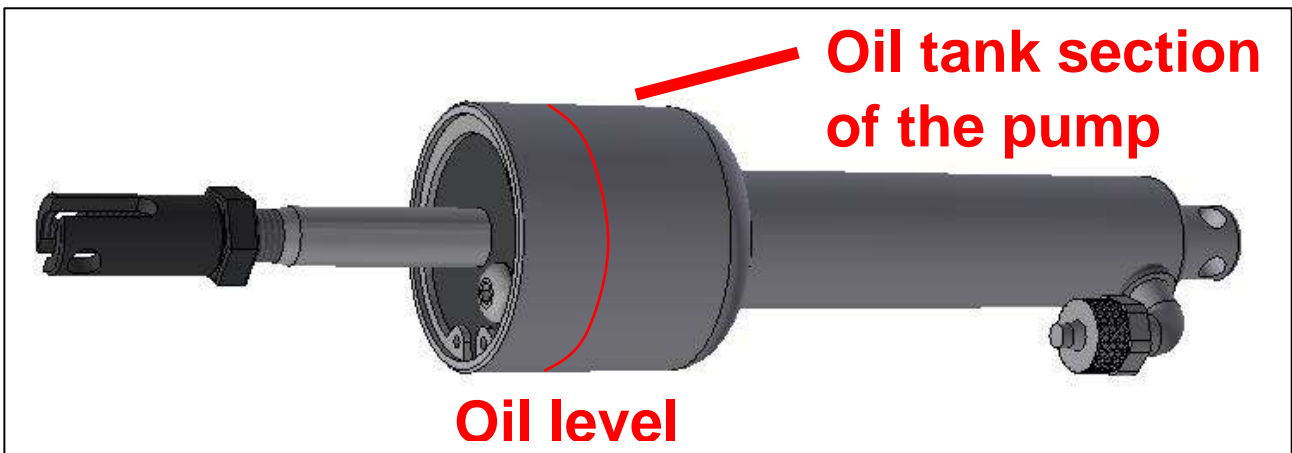

*Figure 47: Brake pump (seen horizontally, not vertically like the airplane installation)*

### 7.5.1. Brakes oil pumps acceptable leaking

Description relative to the maintenance program, especially for the Daily pre-flight check.

The brake oil pump has the oil tank in its upper part, where the section is larger. The cup is just pressed and is not provided a perfect sealing, therefore it is possible to see a very small amount of oil over the cup, especially near the external seeger. The presence of oil is acceptable only if is not in such a quantity that can drop in the aircraft floor. If too much leaking is evaluated, clean the parts and purge the oil pump, removing the excess of oil. Verify the screw of the cup on top of brake pump tank is closed, eventually with sealing glue.

### 7.6. Brake pads change

Replace the brake pads when the residual thickness of the braking material is 3 [mm] thickness. Do not overpass this limit of consumption because the cylinder could lose oil.

To replace the brake pads, unscrew the brake caliper 4 support screw, replace the pads, and then re-install the brake caliper with its screw, locking nuts and bushings. When installing the caliper bushings, lubricate with white grease paying attention to not touch the disc or pads. Always verify the oil level and eventual presence of bubbles in the lines when replacing pads.

	<b>MAINTENANCE MANUAL SAVANNAH S</b>	<b>Doc. No.:</b> MM-SVNH-EN
		<b>Revision:</b> 07
		<b>Rev. Date:</b> 07/11/2022
		<b>Proj. Ref.:</b> SVNH S

## 7.7. Engine oil level verification

### CAUTION

The complete instruction for this verification is described in the approved manufacturer manual of the engine installed. The Maintenance Manual can be downloaded in the technical documentation section of the Rotax website [www.flyrotax.com](http://www.flyrotax.com). The following checklist is just a brief resume

N°	Action
01.01	Verify magnetos switch OFF
01.02	Open the oil tank cup
01.03	Remove the oil dipstick and clean it, paying attention to oil drops outside of the engine compartment
01.04	Rotate the propeller (slowly during the compression) until the oil tank gurgles
01.05	Insert the oil dipstick in the fuel tank
01.06	Remove the oil dipstick and monitor the level
01.06	Verify quality of the oil: clean, not burnt, no impurity
01.08	Insert the dipstick and close the oil cup

*Table 38: Engine oil level*

## 7.8. Oil change

According to the Rotax engine manufacturer approved Maintenance Manual for 912ULS installed model, the following procedure must be followed to drain and change the engine lubricating oil:

- Run the engine and warm up to 40 to 50 [°C] of oil temperature;
- Shut off the engine and check magnetos and master are off;
- Open the engine cowling and let cool down the engine just a couple of minutes;
- If not necessary a complete drainage, jump this step. Differently perform the following actions: disconnect the return line (IN) from the oil tank, remove one spark plug from each cylinder, pressurize at 1 [bar] the vent line of the tank, rotate the engine by hand up to the oil is completely drained out from the return line. If necessary, disconnect also the oil radiator before this procedure and clean it. If necessary clean/flush or replace the oil lines and radiator. When completed, tight the return line on the oil tank at 25 [Nm] and install the spark plugs at 20 [Nm];
- Open the oil tank cup;
- Crank the engine by hand to transfer the oil from crankcase to oil tank, let the oil tank gurgling many times;
- Remove the lower drain screw and its safety wire from the bottom of oil tank;
- Drain the oil (or the remaining oil) from tank and dispose of as per environmental protection;
- If required, clean the oil tank with the dedicated procedure of the engine manufacturer;
- Install on the tank the lower drain screw with a new sealing washer and tight at 25 [Nm] of torque. Perform the safety wiring of the screw;



# MAINTENANCE MANUAL SAVANNAH S

Doc. No.:	MM-SVNH-EN
Revision:	07
Rev. Date:	07/11/2022
Proj. Ref.:	SVNH S

- Unscrew the oil filter and inspect it according to the dedicated procedure of the manufacturer Manual;
- Install a new oil filter according to the dedicated procedure, with oil filled inside and tightening to 3/4 turn after touching the gasket. Mark the filter position with red cross-check glue;
- Unscrew the magnetic plug and inspect it for accumulation of chips, acceptable if smaller than 3 [mm], following the dedicated procedure of the manufacturer Manual;
- Install the magnetic plug after cleaning and tight at 25 [Nm]. Perform the safety wiring of the screw;
- Verify all the system in complete and all hoses, connections are properly closed and safe;
- Add new oil in the oil tank, approximately 3 [lt] to reach maximum level;
- Verify the oil level newly by means of oil dipstick;
- Close the oil cup;
- Switch on the engine and warm up to 50 or 70 [°C];
- Shut off the engine and check magnetos and master are off;
- Open the engine upper cowling and let cool down the engine just a couple of minutes;
- Rotate the propeller up to the oil tank is gurgling and verify newly the oil level,
- If required, replenish the oil up to the proper level (middle between min and max is the optimum). From min to max level of dipstick is approximately 0.5 [lt].

## 7.9. Coolant level verification

### CAUTION

The complete instruction for this verification is described in the approved manufacturer manual of the engine installed. The Maintenance Manual can be downloaded in the technical documentation section of the Rotax website [www.flyrotax.com](http://www.flyrotax.com). The following checklist is just a brief resume

N°	Action
01.01	Verify the engine is cold
01.02	Open the coolant expansion tank cup
01.03	Verify presence of the coolant minimum up to the side transparent indication (dot mark)
01.04	Close the coolant expansion tank cup
01.05	Verify presence of coolant in the overflow bottle minimum up to half of the bottle

Table 39: Coolant level

## 7.10. Coolant change

According to the Rotax engine manufacturer approved Maintenance Manual for 912ULS installed model, the following procedure must be followed to drain and change the engine coolant:

- Open the expansion tank cup;
- Remove the bottom attachment screw (with sealing washer) of the water pump;

A/C: Savannah S	Applies to Generic Serial Number: yy-mm-54-xxxx	Page: 109/132
-----------------	---	---------------

	<h2 style="color: blue;">MAINTENANCE MANUAL SAVANNAH S</h2>	<b>Doc. No.:</b> MM-SVNH-EN
		<b>Revision:</b> 07
		<b>Rev. Date:</b> 07/11/2022
		<b>Proj. Ref.:</b> SVNH S

- From the coolant radiator lower hoses, open the metal clamp and disconnect the hose;
- From the two previous points, let drain entirely the coolant (attention to not wet the ground or other A/C parts, clean if required);
- Fit the bottom attachment screw of the water pump with a new sealing washer and tight at 10 [Nm];
- Fit the hose on the radiator and close the metal clamp up to the maximum tightening;
- Refill newly mixed coolant into the expansion tank at the maximum level. The total coolant quantity is approximately 1.5 [lt];
- Fit the radiator cup;
- Disconnect the vent pipe from the expansion tank (the one connected to the overflow bottle);
- Insert a small pipe into the overflow tank vent pipe and reach the bottom of the overflow bottle;
- Bleed all the liquid in the overflow bottle and if necessary clean this tank by flushing some liquid;
- Alternatively, uninstall the overflow tank from its support and drain/clean by opening the cup, then reinstall correctly, according to the Installation Manual;
- Fill the overflow bottle with coolant up to half height of the tank;
- Connect the overflow vent pipe to the expansion tank and close with a plastic tie-up;
- Run the engine briefly and replenish with clean coolant as required.

### 7.11. Air filter

To check the air filter is necessary to open the airbox by means of the two side screw-nut. Then remove the air filter, check the condition of cleaning, dust, sand, oil, fuel contamination. Clean the air filter by means of compressed air only. If necessary, replace the air filter with a spare new one. Replace also in case of wears of the corner of the filter.

### 7.12. Tyre change

Replace the tyre when time table limits prescribes or tyre expiring date is reached. Replace also in case of excessive wear or when it is flat, not repairable. This is also valid for the inner tube and for tubeless type. According to the assembly manual of the aircraft, uninstall the wheel from the axle first, by lifting the airplane. In case of wheel fairing, uninstall or lift up to the wheel. In case of main wheel, uninstall also the brake caliper (preferred solution in respect of the brake disc uninstallation, because of probable stripped screw). With the wheel on table, unscrew the bolts of the rim. Replace tube or internal o-ring in case of tubeless type. Replace the tyre and re-install the rim flanges together with the hub, close with bolts and stop nuts. In case of tube type wheel, pay attention to not bite the tube on the rim flanges and to align the valve to the rim hole. In case of tubeless type, pay attention to not bite the internal o-ring during the rim flanges closure. Inflate the tyre at proper pressure as indicated in *Chapter 1.23*. Re-install the wheel on the axle, with the correct sequence of washers, bearings, spacer, toothed washer, ring nut, fairing support. Close at adequate torque the ring nut, up to the tire is able to rotate only with good hand force. Verify that the toothed washer is closed

<b>A/C:</b> Savannah S	<b>Applies to Generic Serial Number:</b> yy-mm-54-xxxx	<b>Page:</b> 110/132
------------------------	--	----------------------

	<b>MAINTENANCE MANUAL SAVANNAH S</b>	<b>Doc. No.:</b> MM-SVNH-EN
		<b>Revision:</b> 07
		<b>Rev. Date:</b> 07/11/2022
		<b>Proj. Ref.:</b> SVNH S

safe. Re-install the brake caliper with the brake pads and its bushings, close the bolt/nuts and verify that the assembly is floating on disc. In case of nose (or tail) wheel, install the wheel on its hub, with all the parts and then close the bolt of the axle passing through the fork; perform safety wiring on the axle bolts. Re-install the wheel fairing and leave the aircraft on ground.

### 7.13. Windshield cracks

Stop the crack with a small hole, about 1 [mm] diameter. The improper cleaning or improper detergent of the windows are the main causes of the cracks; consider to change the method. If excessive cracks or scratches are found, which causes the vision blurred or obscured vision, replace the window of windshield with a spare new one.

### 7.14. Wheel fairing cracks

Stop the crack with a small hole, about 2 [mm] diameter. If cracks are found near to the supports of screws area, verify that the fairing can be closed or fixed rigidly before the next flight. If this is not possible, replace the fairing. The fairing can be replaced also in case of any parts delaminated or not structurally rigid anymore.



# MAINTENANCE MANUAL SAVANNAH S

Doc. No.:	MM-SVNH-EN
Revision:	07
Rev. Date:	07/11/2022
Proj. Ref.:	SVNH S

**Left intentionally blank**















# MAINTENANCE MANUAL SAVANNAH S

**Doc. No.:** MM-SVNH-EN

**Revision:** 07

**Rev. Date:** 07/11/2022

**Proj. Ref.:** SVNH S

Change or Repair performed	Operating Hours	Date	Signature

*Table 42: Change or Repair performed*

	<b>MAINTENANCE MANUAL SAVANNAH S</b>	Doc. No.: MM-SVNH-EN
		Revision: 07
		Rev. Date: 07/11/2022
		Proj. Ref.: SVNH S

## ANNEX A - Request of Technical Intervention on the Aircraft

Module to fill-in for a request of technical intervention on an aircraft to I.C.P. Srl workshop.

	<b>I.C.P. Srl</b> Strada Prov.16 - Km 15.150 - Castelnuovo Don Bosco (AT) 14022 Tel.: 011 9927503    Sito Web: www.icp.it e-mail: info@icp.it    P. IVA (IT) 00611190059	SISTEMA QUALITA' CERTIFICATO <b>UNI EN ISO 9001:2015</b> CERT. N. 800458 <b>IATF 16949:2016</b> CERT. N. IATF 90-2
<b>RICHIESTA DI INTERVENTO TECNICO SUL VELIVOLO</b> <b>REQUEST OF TECHNICAL INTERVENTION ON THE AIRCRAFT</b>		
<i>(Da compilarsi a cura del Cliente/ To be filled by Customer)</i>		
Cliente/Customer: _____ Indirizzo/Address: _____ CAP/Postal Code: _____ Località/Town: _____ Telefono/Telephone: _____ e-mail: _____ Velivolo/Aircraft: _____ Matricola/serial number: _____ Ore/hours _____ Motore/Engine: _____ Matricola/serial/number: _____ Ore/hours _____ Problematiche al motore riscontrate dal Cliente/engine problems encountered by the Customer: <input type="checkbox"/> NO <input type="checkbox"/> Si/Yes (specificare il problema/Describe the problem) _____ Problematiche al velivolo riscontrate dal Cliente/aircraft problems encountered by the Customer: <input type="checkbox"/> NO <input type="checkbox"/> Si/Yes (specificare il problema/Describe the problem) _____ <b>L'aereo deve essere corredato del registro di manutenzione del velivolo e del log-book del motore</b> <b><i>The airplane must be accompanied by the maintenance log-book and engine log-book</i></b> Descrizione intervento richiesto / Intervention description required           Data ..... Firma ..... Io sottoscritto ..... accetto integralmente le "condizioni generali per l'intervento tecnico sul velivolo" ed accetto espressamente le clausole 1 (modifica contenuto intervento), 2 (Corresponsabilità), 3 (autorizzazione volo), 4 (esonero responsabilità) <i>I undersigned ..... fully accept the "general conditions for the technical intervention on the airplane" and expressly accept the clauses 1 (modification of the intervention content), 2 (joint responsibility), 3 (flight authorization), 4 (exemption from liability)</i> Data ..... Firma .....		
DRI01		



# MAINTENANCE MANUAL SAVANNAH S

Doc. No.:	MM-SVNH-EN
Revision:	07
Rev. Date:	07/11/2022
Proj. Ref.:	SVNH S

## Condizioni generali per l'intervento tecnico sul velivolo. *General conditions for the technical intervention on the airplane.*

### 1. Modifica contenuto intervento / *modification of the intervention content*

La I.C.P. si riserva la facoltà di modificare il contenuto degli interventi come descritto nell'ordine di lavoro di manutenzione nel caso in cui ciò sia necessario ai fini della sicurezza ed affidabilità del velivolo.

*I.C.P. reserves the right to modify the content of the interventions as described in the request of technical intervention in case it is necessary for the safety and reliability of the aircraft.*

### 2. Corresponsabilità / *joint responsibility*

Nel caso in cui il cliente non sia l'intestatario del velivolo, lo stesso dovrà dichiarare, con sottoscrizione in calce al presente ordine di lavoro di manutenzione di essere autorizzato dal proprietario a fare effettuare gli interventi e che la provenienza del velivolo stesso, nonché di quanto in esso contenuto, è lecita.

*In the event that the customer is not the holder/owner of the aircraft he must declare by signing at the bottom of this order work that he is authorized by the owner to carry out the interventions and that the origin of the aircraft itself as well as its contents is licit.*

### 3. Autorizzazione volo / *flight authorization*

Ove applicabile, il cliente autorizza la I.C.P. srl a compiere eventuali collaudi in volo con il velivolo ai fini di una migliore diagnosi delle condizioni dello stesso, oltre che per verificare il buon esito dell'intervento tecnico. A tal fine dichiara che l'aereo è coperto da assicurazione RCT in corso di validità conforme ai termini di legge.

*Where applicable, the customer authorizes I.C.P. to perform any in-flight tests with the aircraft in order to better diagnose the conditions of the airplane as well as to verify the success of the technical intervention. To this end he declares that the aircraft is covered by RCT insurance in the course of validity in compliance with the terms of the law.*

### 4. Esonero responsabilità / *exemption from liability*

Con la sottoscrizione dell'ordine di lavoro e manutenzione, il Cliente esonera la I.C.P. srl da ogni responsabilità per gli oggetti lasciati sul velivolo, ad eccezione di quelli espressamente accettati per iscritto da I.C.P. e riportati nel predetto ordine

*With the signing of the work and maintenance order, the customer exempts I.C.P. from any responsibility for the objects left on the aircraft except for those expressly accepted in writing by I.C.P. and reported in the aforementioned order.*

DRI01



	<b>MAINTENANCE MANUAL SAVANNAH S</b>	Doc. No.: MM-SVNH-EN
		Revision: 07
		Rev. Date: 07/11/2022
		Proj. Ref.: SVNH S

## ANNEX B - Feedback about ICP Aircraft

Module to fill-in with the purpose to send a feedback to I.C.P. Srl about the airplane.

	Strada Prov.16 - Km 15,150 Castelnuovo Don Bosco (AT) 14022 P. IVA (IT) 00611190059 Tel.: 011 9927503 Website: www.icp.it e-mail: info@icp.it	SISTEMA QUALITA' CERTIFICATO <b>UNI EN ISO 9001:2015</b> <small>CERT. N. SGQ 63/E</small> <b>IATF 16949:2016</b> <small>CERT. N. IATF 92-2</small>
<b>FEEDBACK SU AEREO ICP</b> <i>FEEDBACK ABOUT ICP AIRCRAFT</i>		
<p><u>Da compilarsi a cura del Cliente o del Manutentore del velivolo ed inviare a <a href="mailto:info@icp.it">info@icp.it</a> /</u>  <u>To be filled by the Customer or the Maintenance workshop of the airplane and send to <a href="mailto:info@icp.it">info@icp.it</a></u></p>		
Cliente / Customer: _____ Indirizzo / Address: _____ CAP / Postal Code: _____ Località / Town: _____ Telefono / Telephone: _____ e-mail: _____  Modello velivolo / Aircraft Model: _____ Numero di Serie / Serial Number: _____ Modello Motore / Engine Model: _____ Numero di serie Motore / Engine Serial Number: _____ Elica / Propeller: _____ Numero di serie Elica / Propeller Serial Number: _____ Ore volate / Flight hours: _____		
<b>DICHIARAZIONI / DECLARATIONS:</b>		
Dichiaro che il velivolo è stato utilizzato secondo quanto prescritto dal documento Manuale di Volo (POH) approvato e aggiornato da I.C.P. Srl unicamente / I declare that the aircraft has been used according to the prescriptions of the Pilot's Operating Handbook document approved and updated by I.C.P. Srl uniquely. <input type="checkbox"/> SI / YES <input type="checkbox"/> NO                      Firma / Signature: _____ Se NO, specificare la variazione / If NO, specify variations: _____ _____		
Dichiaro che il velivolo è stato mantenuto e revisionato secondo quanto prescritto dal documento Manuale di Manutenzione (MM) approvato e aggiornato da I.C.P. Srl unicamente / I declare that the aircraft has been maintained and revisioned according to the prescriptions of the Maintenance Manual document approved and updated by I.C.P. Srl uniquely. <input type="checkbox"/> SI / YES <input type="checkbox"/> NO                      Firma / Signature: _____ Se NO, specificare la variazione / If NO, specify variations: _____ _____		
		Page: 1/2 <small>DFB00</small>



	<b>MAINTENANCE MANUAL SAVANNAH S</b>	Doc. No.: MM-SVNH-EN
		Revision: 07
		Rev. Date: 07/11/2022
		Proj. Ref.: SVNH S

### ANNEX C - Maintenance work record Model

**Info:** copy or print directly the *Maintenance Logbook Model* (Pag. 97 to 106) and fill-in the table related only to the maintenance actions that must be carried out. This Model could be eventually attached to each work registered in the *Chapter 8* to complete the information about the actions executed.

<b>Aircraft Model:</b>	Savannah S
<b>Serial Number:</b>	
<b>Engine operating hours:</b>	
<b>Flight hours (if differs):</b>	
<b>Type of maintenance Hours / Time:</b>	

**ACTIONS ON ENGINE AND PROPELLER (refer to the proper engine or propeller Maintenance Manual):**

**NOTE OF MAINTENANCE (Replaced parts, unusual maintenance, repairs, other actions):**

**TEST FLIGHT (Flight time, airfield, operator, note, other actions):**

**Operator and / or Responsible signature**

**Note:** attach to the present form the Maintenance Checklist copy, performed and signed in the relevant section for the maintenance performed.



# MAINTENANCE MANUAL SAVANNAH S

**Doc. No.:** MM-SVNH-EN

**Revision:** 07

**Rev. Date:** 07/11/2022

**Proj. Ref.:** SVNH S

## Maintenance Checklist

**INSTRUCTION:** use the following table to keep record of each single point of the scheduled maintenance performed on the aircraft.

In the column “Check”, mark “V” if the action is already performed and mark “N/A” where it is Not Applicable for the maintenance work list under consideration (i.e.: point not present). Instead of the checks, is also possible to add the signature of the person who performed the maintenance point.

The column “Ind.Ck.” stands for the Independent Check, which identifies few verification points only, the ones not highlighted grey, that are required to be additionally verified by an independent personnel eventually involved in the maintenance organization.

<b>Scheduled Maintenance hours:</b>				
<b>Structure / System</b>	<b>N°</b>	<b>Check</b>	<b>Ind.Ck.</b>	<b>Note</b>
Aircraft Safetying	00.01			
	00.02			
	00.03			
	00.04			
	00.05			
Fuselage	01.01			
	01.02			
	01.03			
	01.04			
	01.05			
	01.06			
	01.07			
	01.08			
	01.09			
	01.10			
	01.11			
	01.12			
	01.13			
	01.14			
	01.15			
	01.16			
	01.17			
	01.18			
	01.19			
	01.20			
	01.21			
	01.22			
	01.23			
	01.24			
Right Wing	02.01			
	02.02			
	02.03			



# MAINTENANCE MANUAL SAVANNAH S

**Doc. No.:** MM-SVNH-EN

**Revision:** 07

**Rev. Date:** 07/11/2022

**Proj. Ref.:** SVNH S

Structure / System	N°	Check	Ind.Ck.	Note
Right Wing	02.04			
	02.05			
	02.06			
	02.07			
	02.08			
	02.09			
	02.10			
	02.11			
	02.12			
	02.13			
	02.14			
	02.15			
	02.16			
Right Flaperon	03.01			
	03.02			
	03.03			
	03.04			
	03.05			
	03.06			
	03.07			
	03.08			
Left Wing	04.01			
	04.02			
	04.03			
	04.04			
	04.05			
	04.06			
	04.07			
	04.08			
	04.09			
	04.10			
	04.11			
	04.12			
	04.13			
	04.14			
	04.15			
	04.16			
	04.17			
04.18				
04.19				
04.20				



# MAINTENANCE MANUAL SAVANNAH S

**Doc. No.:** MM-SVNH-EN

**Revision:** 07

**Rev. Date:** 07/11/2022

**Proj. Ref.:** SVNH S

Structure / System	N°	Check	Ind.Ck.	Note
Left Flaperon	05.01			
	05.02			
	05.03			
	05.04			
	05.05			
	05.06			
	05.07			
	05.08			
Stabilizer	06.01			
	06.02			
	06.03			
	06.04			
	06.05			
	06.06			
	06.07			
	06.08			
	06.09			
	06.10			
	06.11			
Elevator	07.01			
	07.02			
	07.03			
	07.04			
	07.05			
	07.06			
	07.07			
	07.08			
	07.09			
	07.10			
	07.11			
Trim Tab	08.01			
	08.02			
	08.03			
	08.04			
	08.05			
Vertical Tail (Fin)	09.01			
	09.02			
	09.03			
	09.04			
	09.05			
	09.06			
	09.07			



# MAINTENANCE MANUAL SAVANNAH S

**Doc. No.:** MM-SVNH-EN

**Revision:** 07

**Rev. Date:** 07/11/2022

**Proj. Ref.:** SVNH S

Structure / System	N°	Check	Ind.Ck.	Note
Vertical Tail (Fin)	09.08			
	09.09			
Rudder	10.01			
	10.02			
	10.03			
	10.04			
	10.05			
	10.06			
	10.07			
	10.08			
	10.09			
	10.10			
Flight Control System	11.01			
	11.02			
	11.03			
	11.04			
	11.05			
	11.06			
	11.07			
	11.08			
	11.09			
	11.10			
	11.11			
	11.12			
	11.13			
	11.14			
	11.15			
	11.16			
	11.17			
11.18				
11.19				
11.20				
Main landing gear	12.01			
	12.02			
	12.03			
	12.04			
	12.05			
	12.06			
	12.07			
	12.08			
	12.09			
	12.10			



# MAINTENANCE MANUAL SAVANNAH S

**Doc. No.:** MM-SVNH-EN

**Revision:** 07

**Rev. Date:** 07/11/2022

**Proj. Ref.:** SVNH S

Structure / System	N°	Check	Ind.Ck.	Note
Main landing gear	12.11			
	12.12			
	12.13			
	12.14			
Main landing gear tail dragger (if configured with)	12b.01			
	12b.02			
Nose landing gear	13.01			
	13.02			
	13.03			
	13.04			
	13.05			
	13.06			
	13.07			
	13.08			
	13.09			
	13.10			
	13.11			
	13.12			
	13.13			
	13.14			
13.15				
13.16				
Tail landing gear (if configured with)	13b.01			
	13b.02			
	13b.03			
	13b.04			
	13b.05			
	13b.06			
	13b.07			
	13b.08			
	13b.09			
Engine cowling	14.01			
	14.02			
	14.03			
Propeller	15.01			
	15.02			
	15.03			
	15.04			
	15.05			





# MAINTENANCE MANUAL SAVANNAH S

Doc. No.: MM-SVNH-EN

Revision: 07

Rev. Date: 07/11/2022

Proj. Ref.: SVNH S

Structure / System	N°	Check	Ind.Ck.	Note
Propeller	15.06			
	15.07			
	15.08			
Engine	16.01			
	16.02			
	16.03			
	16.04			
	16.05			
	16.06			
	16.07			
	16.08			
	16.09			
	16.10			
	16.11			
	16.12			
	16.13			
	16.14			
	16.15			
	16.16			
	16.17			
	16.18			
16.19				
16.20				
16.21				
Powerplant controls	17.01			
	17.02			
	17.03			
	17.04			
	17.05			
	17.06			
	17.07			
	17.08			
	17.09			
	17.10			
	17.11			
	17.12			
	17.13			
	17.14			
Fuel system	18.01			
	18.02			
	18.03			
	18.04			
	18.05			



# MAINTENANCE MANUAL SAVANNAH S

Doc. No.: MM-SVNH-EN

Revision: 07

Rev. Date: 07/11/2022

Proj. Ref.: SVNH S

Structure / System	N°	Check	Ind.Ck.	Note
Fuel system	18.06			
	18.07			
	18.08			
	18.09			
	18.10			
	18.11			
	18.12			
	18.13			
	18.14			
	18.15			
	18.16			
	18.17			
	18.18			
	18.19			
	18.20			
18.21				
18.22				
18.23				
Water system	19.01			
	19.02			
	19.03			
	19.04			
	19.05			
	19.06			
	19.07			
	19.08			
	19.09			
	19.10			
	19.11			
	19.12			
Oil system	20.01			
	20.02			
	20.03			
	20.04			
	20.05			
	20.06			
	20.07			
	20.08			
	20.09			
	20.10			



# MAINTENANCE MANUAL SAVANNAH S

**Doc. No.:** MM-SVNH-EN

**Revision:** 07

**Rev. Date:** 07/11/2022

**Proj. Ref.:** SVNH S

Structure / System	N°	Check	Ind.Ck.	Note
Oil system	20.11			
	20.12			
	20.13			
	20.14			
	20.15			
	20.16			
Intake system	21.01			
	21.02			
	21.03			
	21.04			
	21.05			
	21.06			
	21.07			
	21.08			
	21.09			
	21.10			
Exhaust system	22.01			
	22.02			
	22.03			
Cabin heating	23.01			
	23.02			
	23.03			
Electrical system	24.01			
	24.02			
	24.03			
	24.04			
	24.05			
	24.06			
	24.07			
	24.08			
	24.09			
Marking and placards	25.01			
Ground run up check	26.01			
	26.02			
	26.03			
	26.04			
	26.05			
	26.06			
	26.07			
	26.08			



# MAINTENANCE MANUAL SAVANNAH S

**Doc. No.:** MM-SVNH-EN

**Revision:** 07

**Rev. Date:** 07/11/2022

**Proj. Ref.:** SVNH S

Structure / System	N°	Check	Ind.Ck.	Note
Flight check	27.01			
	27.02			
	27.03			
	27.04			
	27.05			
	27.06			
	27.07			
	27.08			
	27.09			
	27.10			
	27.11			
Avionics	28.01			
Other equipment	29.01			
	29.02			
	29.03			
	29.04			
	29.05			
Maintenance close out	30.01			
	30.02			
	30.03			
	30.04			
	30.05			
	30.06			

**Colour legend:**

Colour	Meaning
	50 hrs maintenance
	100 hrs maintenance
	200 hrs maintenance
	1000 hrs maintenance
	2000 hrs maintenance
	To Apply, to fill
	Not Applicable, not to fill